

WINGNUT WINGS



Albatros B.II Early

1/32 Scale

The Albatros B.II is perhaps unique amongst aircraft of the First World War in that production commenced in 1913, continued throughout the war and after the Armistice. The Albatros B.II was initially known simply as the Albatros DD (Doppledecker) and was developed in parallel with the DDK which appeared the same except it was slightly longer and fitted with longer 3 bay wings (and would eventually become known as the Albatros B.1). Like other German B type aircraft it was powered by 100hp to 120hp engines manufactured by Daimler-Mercedes, Argus and Benz with the pilot positioned in the rear cockpit with a steering wheel control column and the passenger in the front seat.

The Albatros B.II went through numerous minor and major changes during its relatively long lifespan and manufacture by 7 different companies but managed to emerge 6 years later appearing essentially the same. The box section fuselage was constructed from spruce & ash longerons and frames covered with 3-ply wood. The unequal span wings were fabric covered as were the steel tube framed ailerons and tailplane. Interplane, cabane and undercarriage struts were of steel tube construction. Very early aircraft featured a smaller fin with a rounded rudder and a Scheitelk uler 'Brow Radiator' mounted above the engine which almost completely obstructed the view forward. Early production Albatros B.II, as featured in this model, had a larger fin with a triangular rudder and Hazet radiators fixed to each side of the fuselage. Conservation of steel would lead to the development of the Albatros B.IIa which replaced the sole steel tube frame in the fuselage with wood and eventually the steel tube interplane and undercarriage struts would also be replaced by wooden items. Later developments included replacing the side mounted Hazet radiators with a single Windhoff item mounted in front of the leading edge of the top wings, replacing the control wheel with a stick type control column (necessitating the re-routing of the aileron & elevator control cables), dual controls for pilot training, moving the tail skid forward, adding additional struts under the tailplane, numerous exhaust styles and various positions & shapes of gravity fuel tank; almost all of which could be found retrofitted to earlier production aircraft as needed along with various interchangeable B.1 & C.1 components.

Unarmed B type aircraft like the Albatros B.II were initially utilized for reconnaissance but shortly after hostilities began airmen started carrying small bombs and personal firearms. Eventually many were fitted with bomb racks and various captured machine guns on improvised mountings. With the advent of purpose built armed and more powerful C type aircraft from mid 1915 (the Albatros C.1 was essentially a slightly redesigned Albatros B.II powered by a 150hp or 160hp engine with the gunner in the rear cockpit) the unarmed and underpowered B type aircraft were slowly relegated to training duties. Any history of this important aircraft here is of necessity very brief, therefore we encourage you to seek out the references mentioned below for a more thorough understanding.

WW1 colour schemes are contentious at the best of times and we have done our best to provide what we consider to be accurate painting information for this model. Because the Albatros B.II was in production and service for such a long time and manufactured by numerous different companies they can be seen in a wide variety of finishes. Photographic evidence indicates that the fuselage of many Albatros B.II were finished with pale yellow or dark red brown varnishes, unfortunately each could appear as dark as the other in photographs depending on the film type and/or filters. Additionally many were painted in pale colours which appear to have been light grey-green, light blue and even white for aircraft destined for training duties. Fabric wings and tailplane components appear to have been covered with unbleached Clear Doped Linen (CDL), bleached (white) linen, dyed linen or painted with translucent and opaque camouflage colours or with a tightly mottled/spotted finish which was probably sponge rolled onto the fabric. Albatros B.II still serving on the front lines in 1916 would have received field applied camouflage finishes of various brown and/or green colours. Metal brackets and fittings appear to have been painted with the usual light grey-green protective finish unless they were overpainted along with the fuselage. National markings could encompass the full range of cross styles depending on when the aircraft was manufactured. Additionally, major components of the Albatros B.II remained interchangeable throughout production meaning that salvaged parts could be retrofitted leading to a variety of different crosses and fabric finishes appearing on the same aircraft. The various camouflage schemes and personal markings applied to German aircraft of the Great War have attracted more than their fair share of debate over the years and, while we have been as meticulous as we could be, I'm sure some will not find our choices to their liking and impassioned debate will continue to rage on amongst modellers.

Richard Alexander 2015

Wingspan:	Length:	Max Weight:	Max Speed:
12.8m (42ft)	7.76m (25.46 ft)	1165kg (2568 lb)	105kph (65 mph)
No. Manufactured:	Production:	Armament:	
(B.II & B.IIa) Approx 4900	1913 - 1919	50kg (110 lb) of bombs and various guns on improvised mounts	
Ceiling:	Engine:		
3000m (9842ft)	Daimler-Mercedes 100hp D.1 & 120hp D.II, Argus 100hp As.1 & 120hp As.II, Benz 110hp Bz.II		

References:









Albatros B.II Windsock Datafile 93, PM Grosz 2002 - Flight, 4 April 1914 & 26 November 1915 - wwi-models.org - Albatros B.II, Aero Photogallery 1, Piotr Mrozowski 2005 - Colin Owers - 1914-18 Aviation Heritage Trust - The Vintage Aviator LTD - Private Collections.

Albatros B.II Early

1/32 Scale

- Warning:** Choking hazard. Keep small parts and plastic bags away from children. Use glue and paint in a well ventilated area. Always wear protective eyewear when cutting and a protective mask when painting, gluing and sanding. Do not breathe dust from polyurethane resin parts (if included). Beware of sharp edges on metal parts.
- Assembly:** **Read all the instructions carefully before starting assembly.** Use glue intended for plastic models. Assemble metal and resin parts (if included) using Cyanoacrylate (CA) or epoxy glue. Before assembly select a marking option and note optional parts required in instructions.
- Rigging:** If installing rigging please drill out all location holes with a 0.5mm drill bit to a depth of at least 1mm.
- Painting:** Only use paints **designed and suitable** for plastic model kitsets.
- Decals:** Cut out each decal as required. Soak in warm water for 15 seconds. Slide off backing paper onto **gloss painted surface of model (not just clear coated plastic)**. For large decals it is helpful to apply a drop of water to the area they are being applied to. This will make it easier to maneuver them into the correct position.

Hints & Tips: Please visit our website for additional photos, hints and tips to assist you in getting the best result from your Wingnut Wings model.

1	Construction Step		Choose		Attention		Remove
A1	Part Number		Do Not Cement		Option		Drill
5	Decal		Cement For Metal		Other Side		Paint Colour
P1	Photo Etch Part						

	All colours	Tamiya	Humbrol	Federal Standard
a	Brass	X31	54	
b	Gun Metal	X10	27004	
c	Aluminium	XF16	27001	
d	Black - semi gloss	X18	85	
e	Dark Wood - semi gloss	XF68*	64*	30111*
f	Leather - semi gloss	XF52	62	30219
g	Grey Green - matt	XF76	-	24424
h	Rubber Dark - matt	XF69	66	35042
i	Bleached Linen - semi gloss	X2(x10) + XF55(x1)	22(x10) + 148(x1)	37886
j	White - semi gloss	XF2	34	
k	Rust - matt	XF9	113	20045
l	Grey - matt	XF22	92	24159
m	Unbleached Linen (CDL) - semi gloss	XF57	121	20475
n	Copper	XF6	12	
o	Light Wood - semi gloss	XF59*	93*	33245*
p	Light Blue - semi gloss	X2(x10) + XF18(x1)	22(x10) + 96(x1)	25550
q	Steel	XF56	27003	
r	Khaki - matt	XF49	72	30277
s	Red-Brown varnish - semi gloss	X19(x2) + X27(x1)	-	
t	Yellow varnish - gloss	X22(x3) + X24(x1)	-	
u	Pale Cream Yellow - semi gloss	XF2(x5) + XF59(x1)	71	13523
v	Rubber Light - matt	XF19	64	36463
w	Red - semi gloss	X7	19	11350

1 **Note:** Apply clear varnish to achieve the desired gloss or semi-gloss finish. * See our website for hints and tips on painting wood.

1 COCKPIT

! Apply optional wood grain decals to gloss painted surface (not just clear coated plastic).

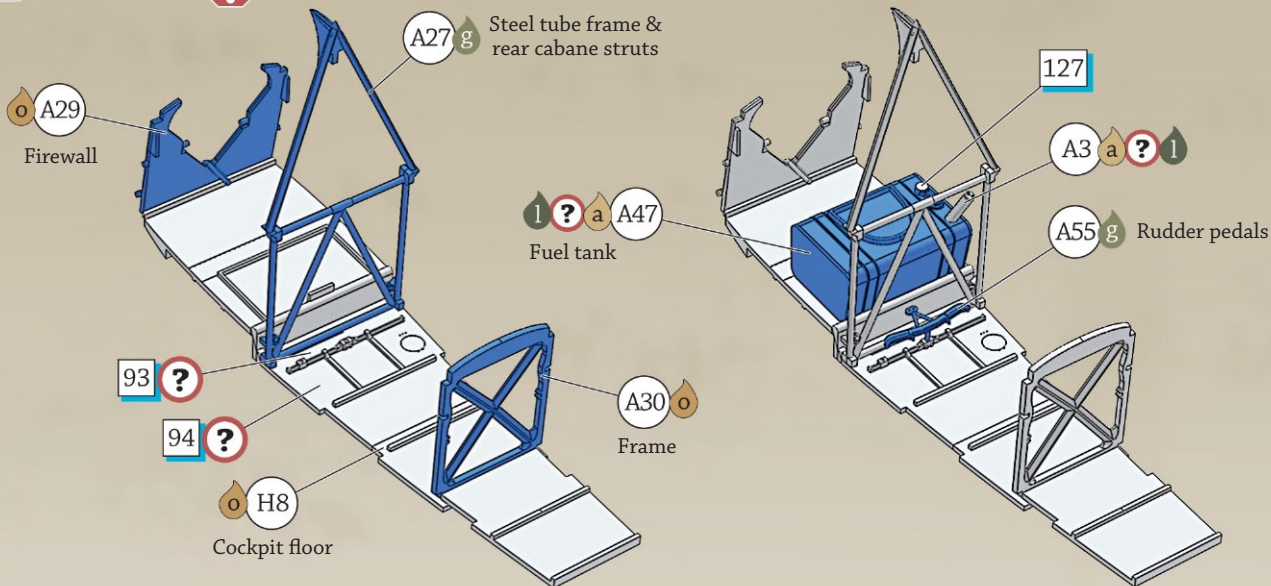

ABCE ? i Engine controls - port side of the fuselage

D

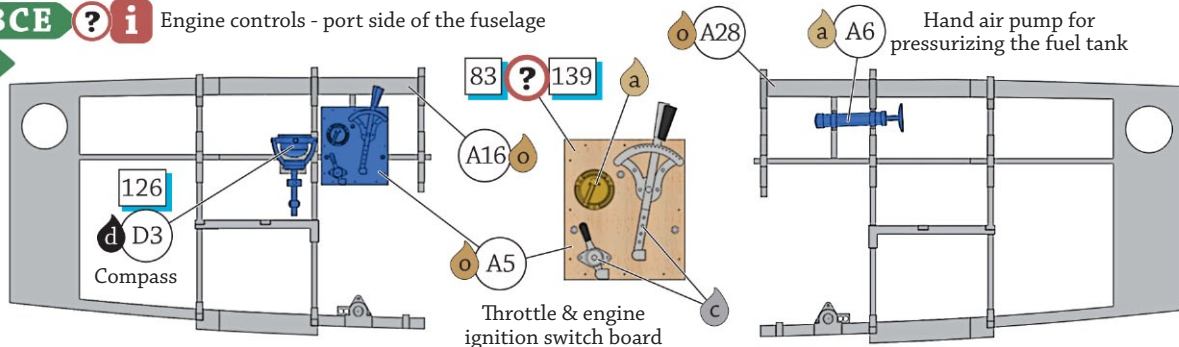

ABCE ? ii Engine controls - starboard side of fuselage

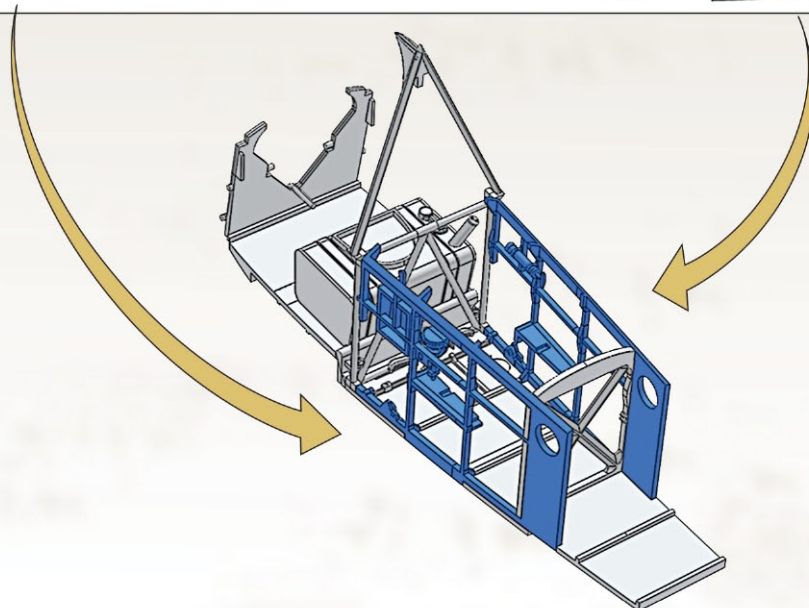
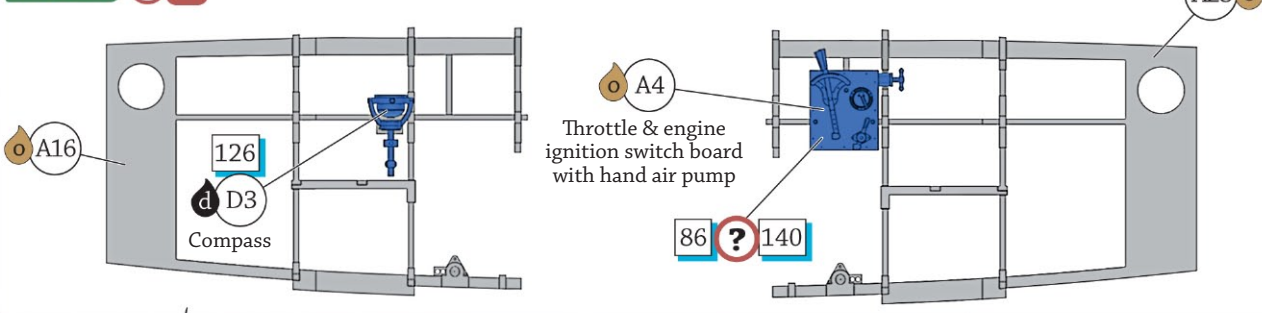

2 COCKPIT continued

ABCE ? i Port engine controls

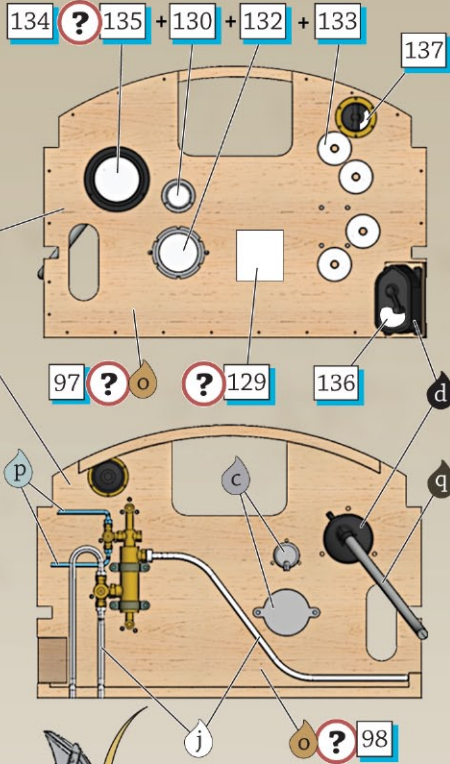
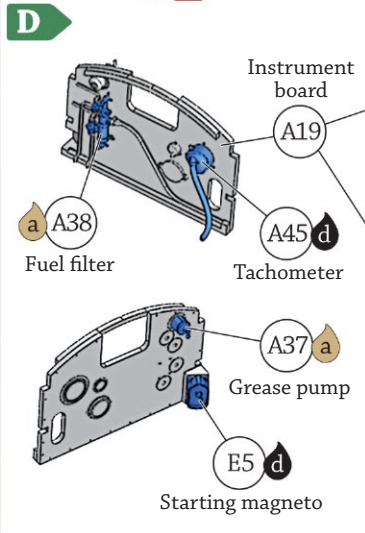

ABCE ? ii Starboard engine controls

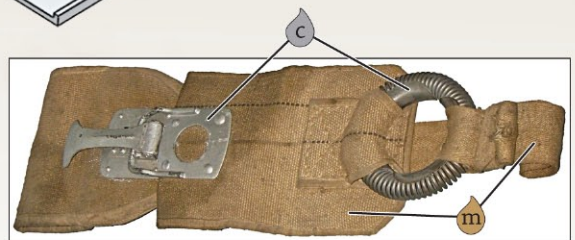
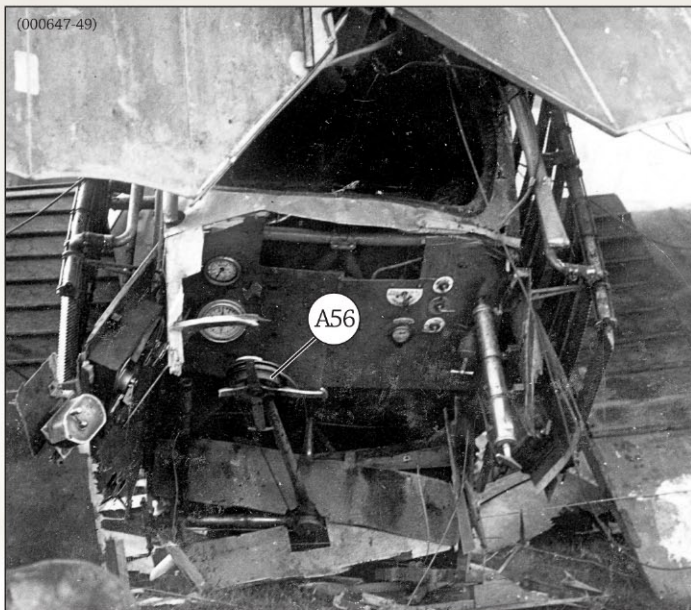
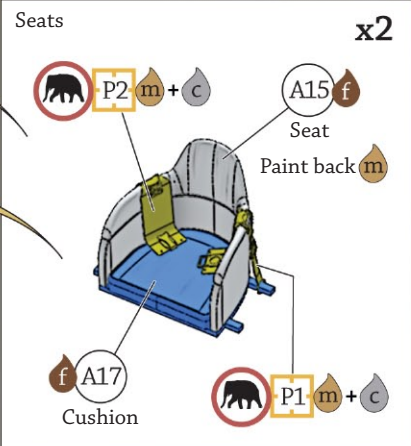
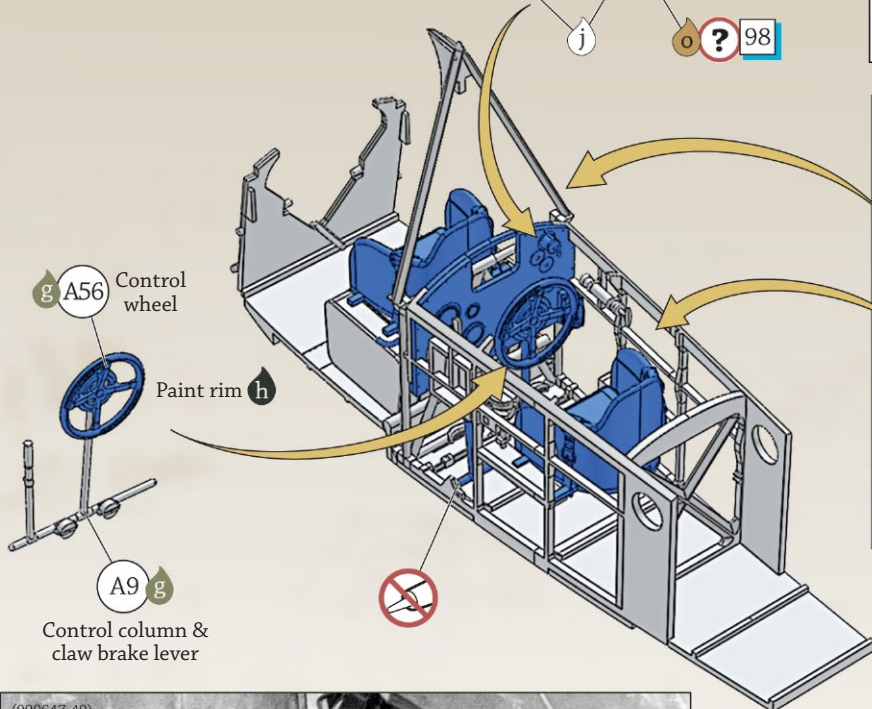
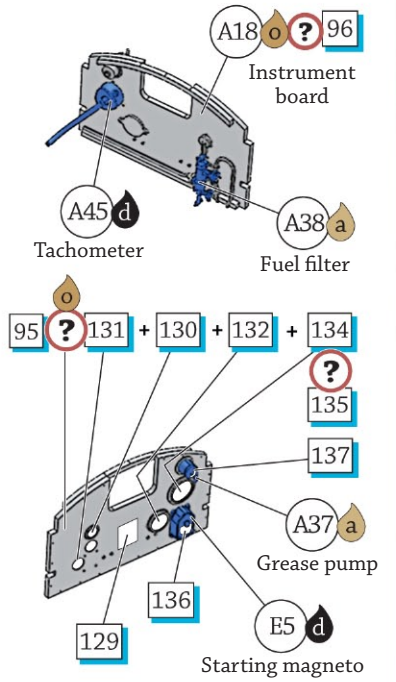

^ Common type of safety belt found in German two-seat aircraft as displayed in the Deutches Technikmuseum Berlin.

< Rear cockpit detail from the crashed Albatros B.II shown on page 22. Note the hand air pump (A6), destroyed control wheel (A56) and layout of the instruments. There were many variations in instrument board layouts on the Albatros B.II so while we have been as meticulous as we could, our model will not be accurate for all versions. All following photos show 100hp-120hp Daimler-Mercedes powered early production Albatros B.II unless noted otherwise.

INTERIOR PAINTING GUIDE

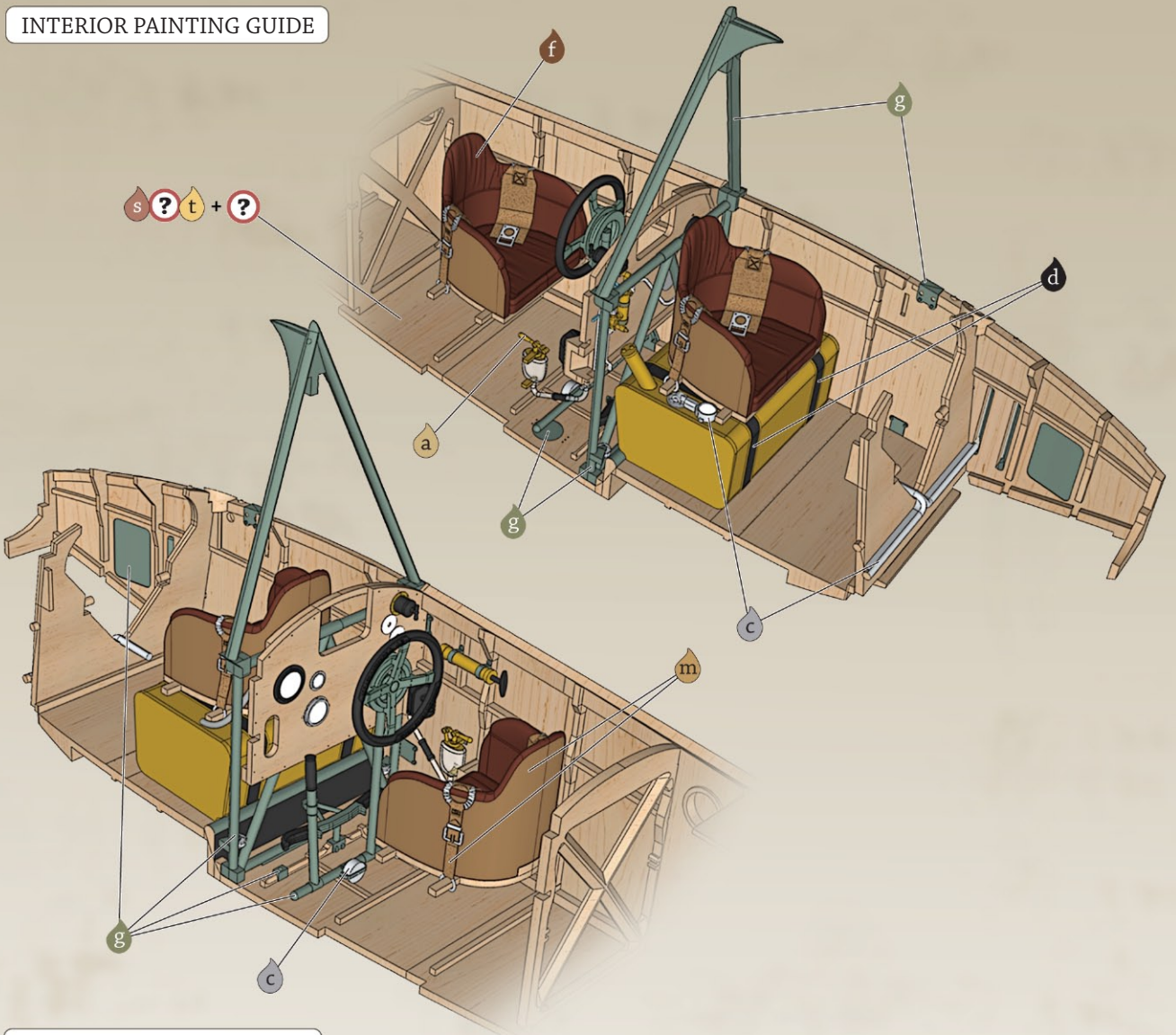

INTERNAL RIGGING GUIDE

Rigging material not supplied

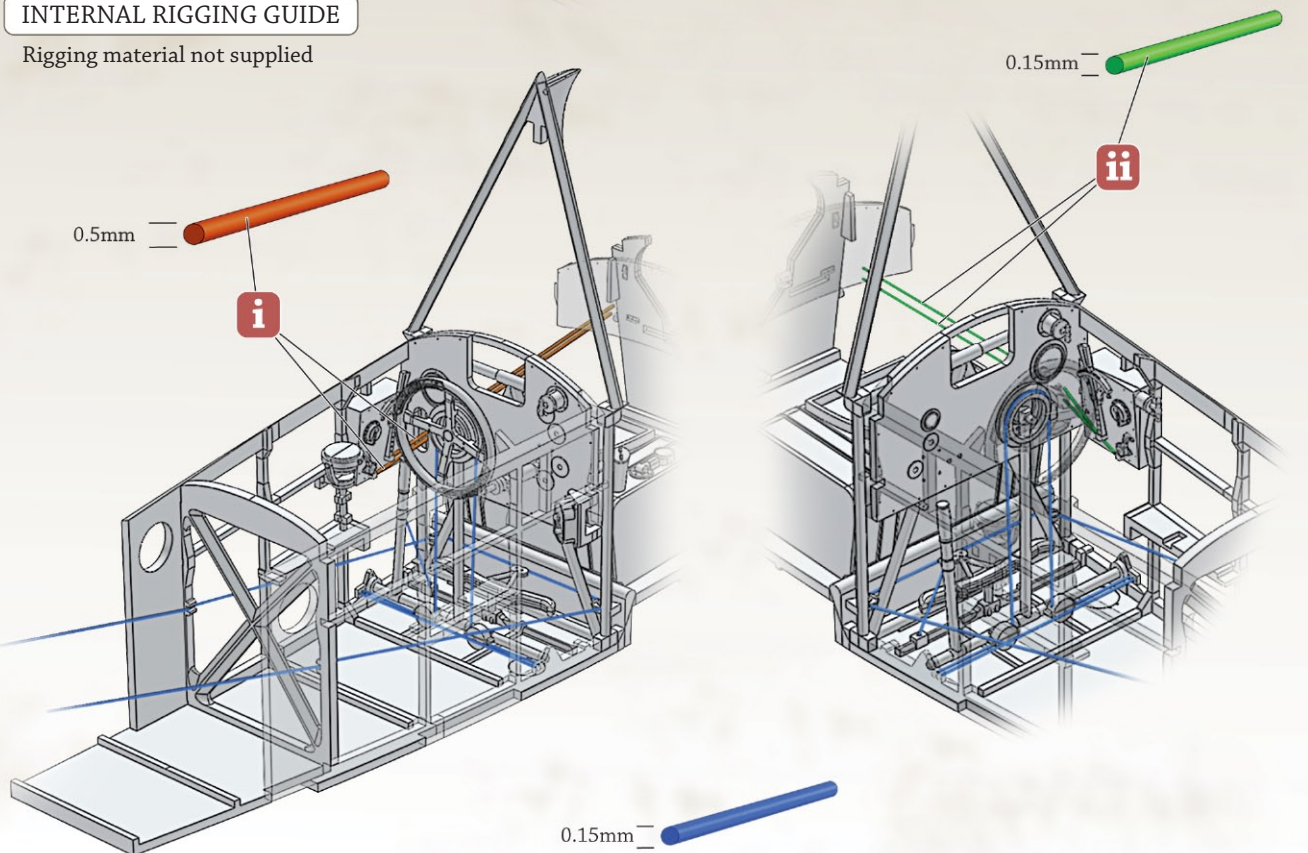

3 FUSELAGE

! Apply optional wood grain decals to gloss painted surface (not just clear coated plastic).

? 89 ? 90 ? 92

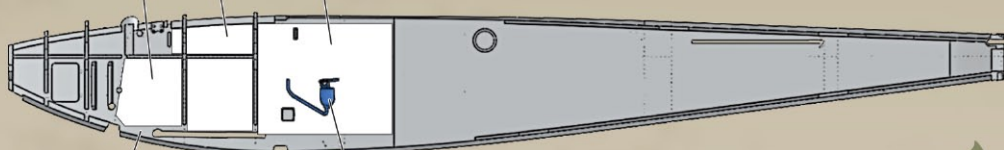

Paint metal brackets & fittings **g**

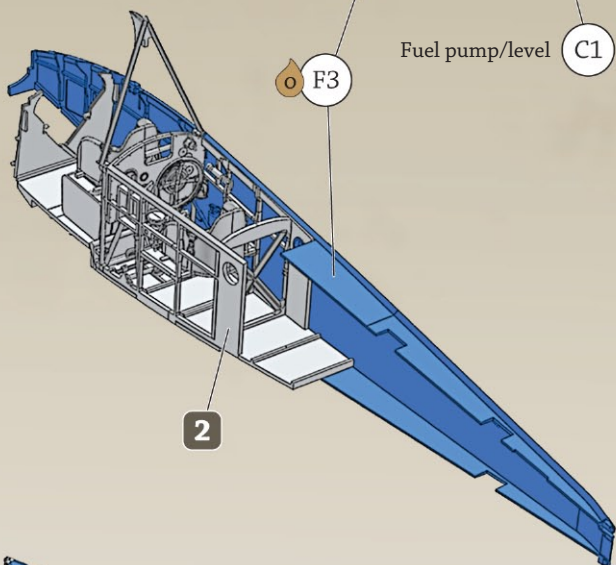

Fuel pump/level **C1**

F3

2

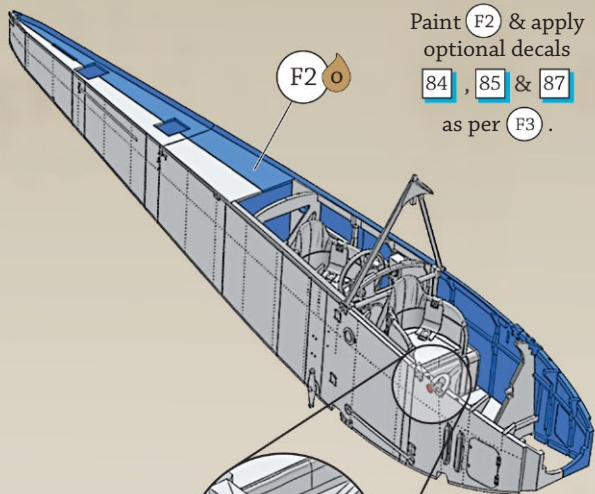

Paint **F2** & apply optional decals

84, **85** & **87**

as per **F3**.



Remove for high water pipes

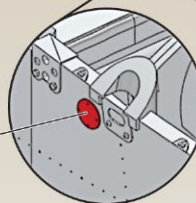

0.15mm

Rigging material not supplied

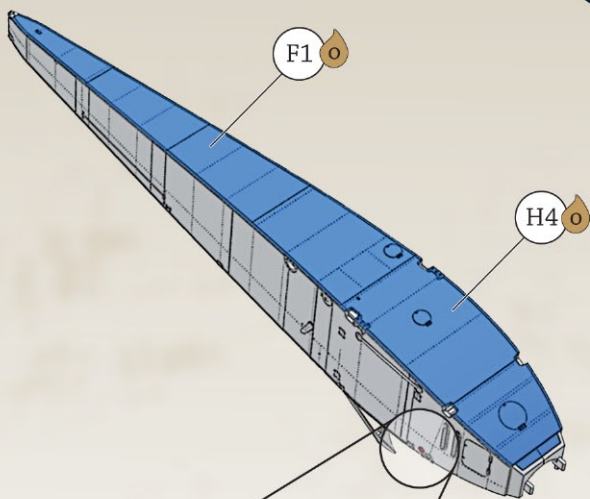

F1

H4

2

91 **88** ? **A32**

82 ?

A41 Map board

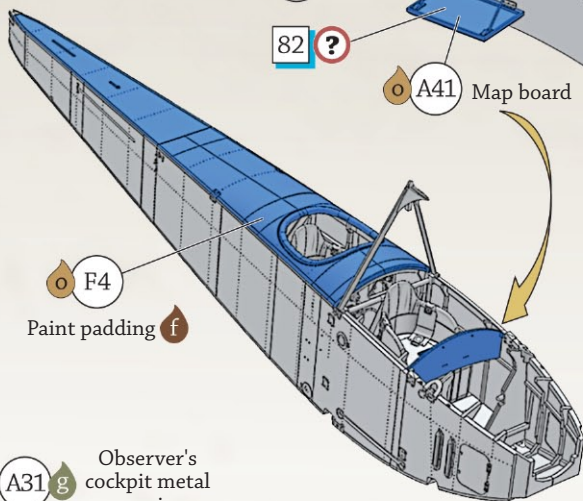

F4
Paint padding **f**

A31 **g**
Observer's cockpit metal coaming

Paint padding **f**

Paint inside **c**

Starboard engine bearer & oil tank **e** **A52**

Paint oil tank **a**

A36 **e**
Port engine bearer



Remove for high water pipes

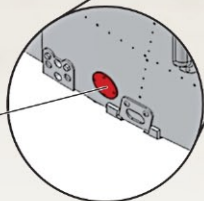

4 DAIMLER-MERCEDES 100hp D.I & 120hp D.II ENGINE

! Daimler-Mercedes D.I & D.II aircraft engines are almost indistinguishable from one another and while we have tried our best to identify the appropriate engine for each colour scheme it is quite possible we have not been completely successful.

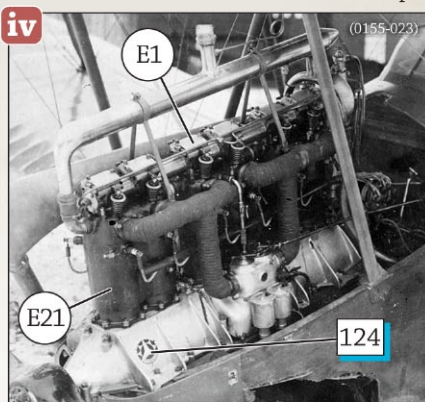
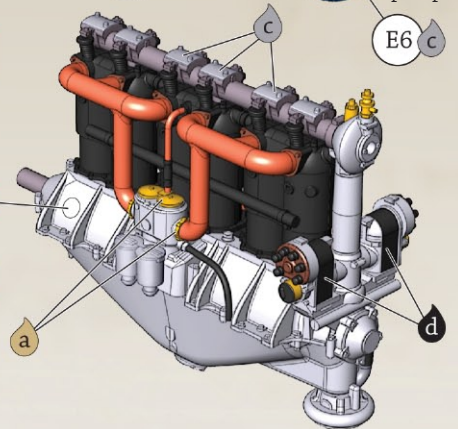
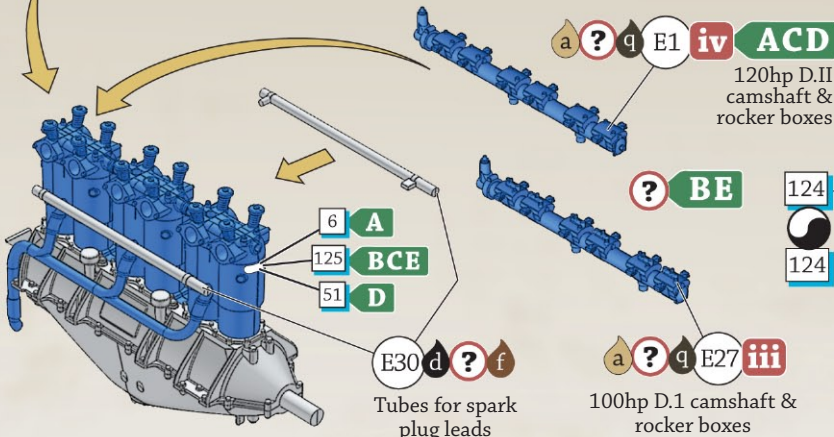
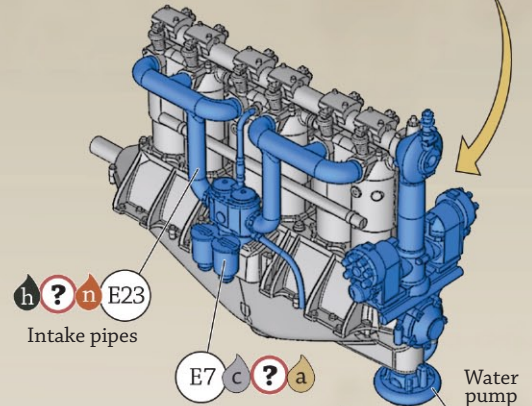
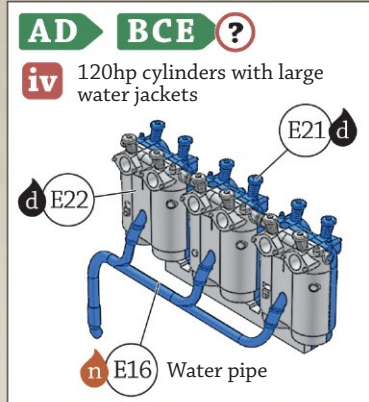
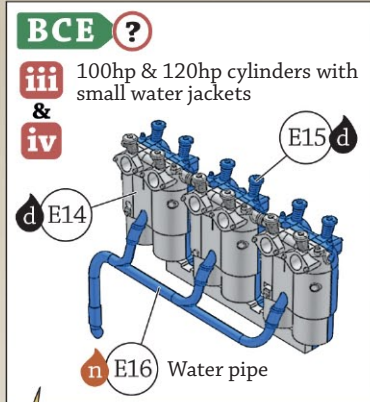
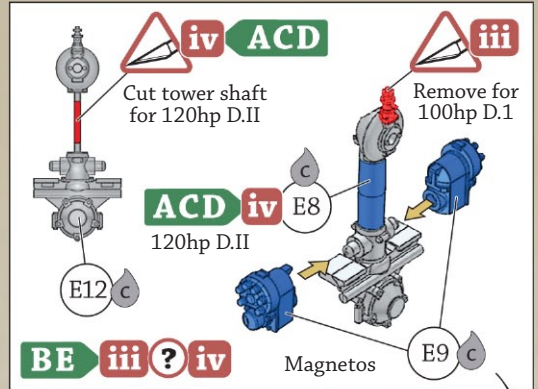
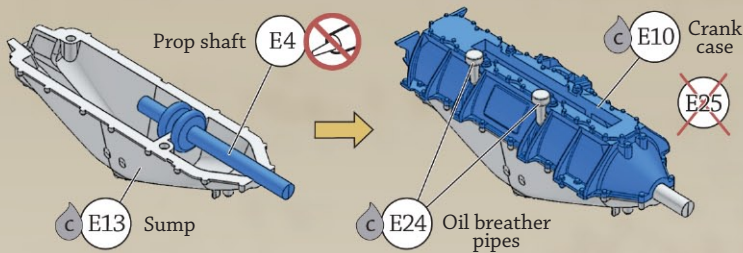

< The crash of this unidentified DFW B.1 allows us a rare view of its elusive early Daimler-Mercedes engine. The style of camshaft & rocker box (E1) identify this as a 120hp D.II engine and the larger water jacket cylinders (E21) + (E22) would tend to indicate a later production item or field upgrade.

> 100hp Daimler-Mercedes D.I engine from the Flieger-Flab-Museum in Dubendorf. Note the style of camshaft & rocker boxes (E27).



< 120hp Daimler-Mercedes D.II engine from the Zagreb museum. Note the style of camshaft (E6) & rocker boxes (E1), tower shaft cover and air pump at the top rear.

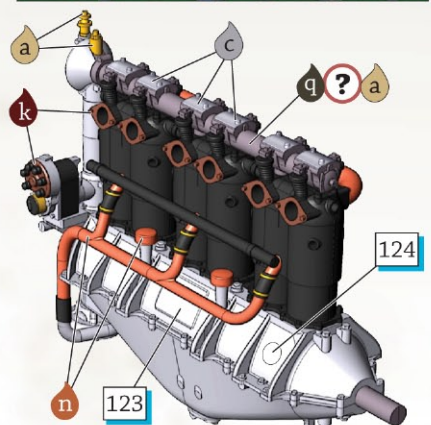

5 HAZET RADIATORS

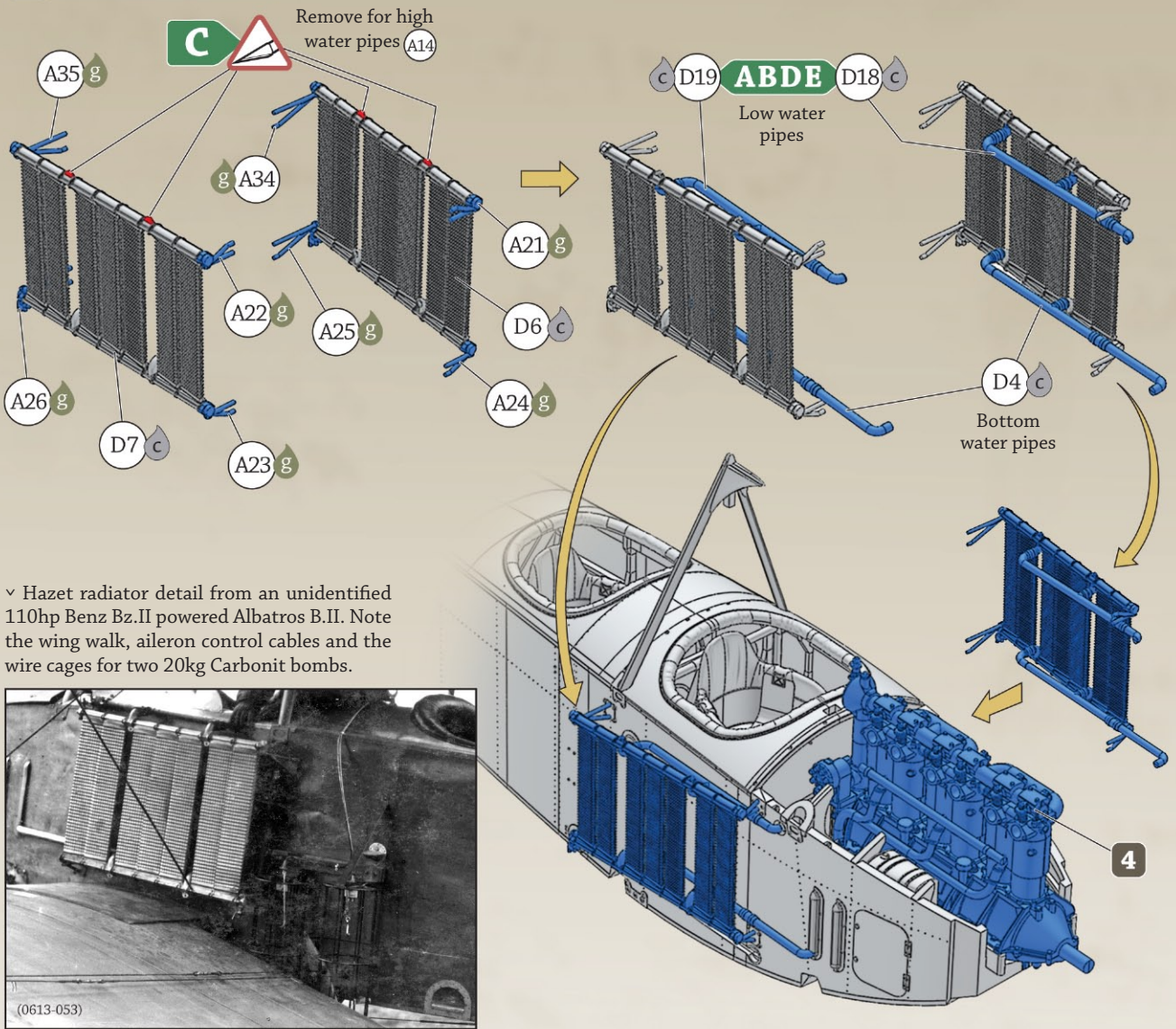

✓ Hazet radiator detail from an unidentified 110hp Benz Bz.II powered Albatros B.II. Note the wing walk, aileron control cables and the wire cages for two 20kg Carbonit bombs.

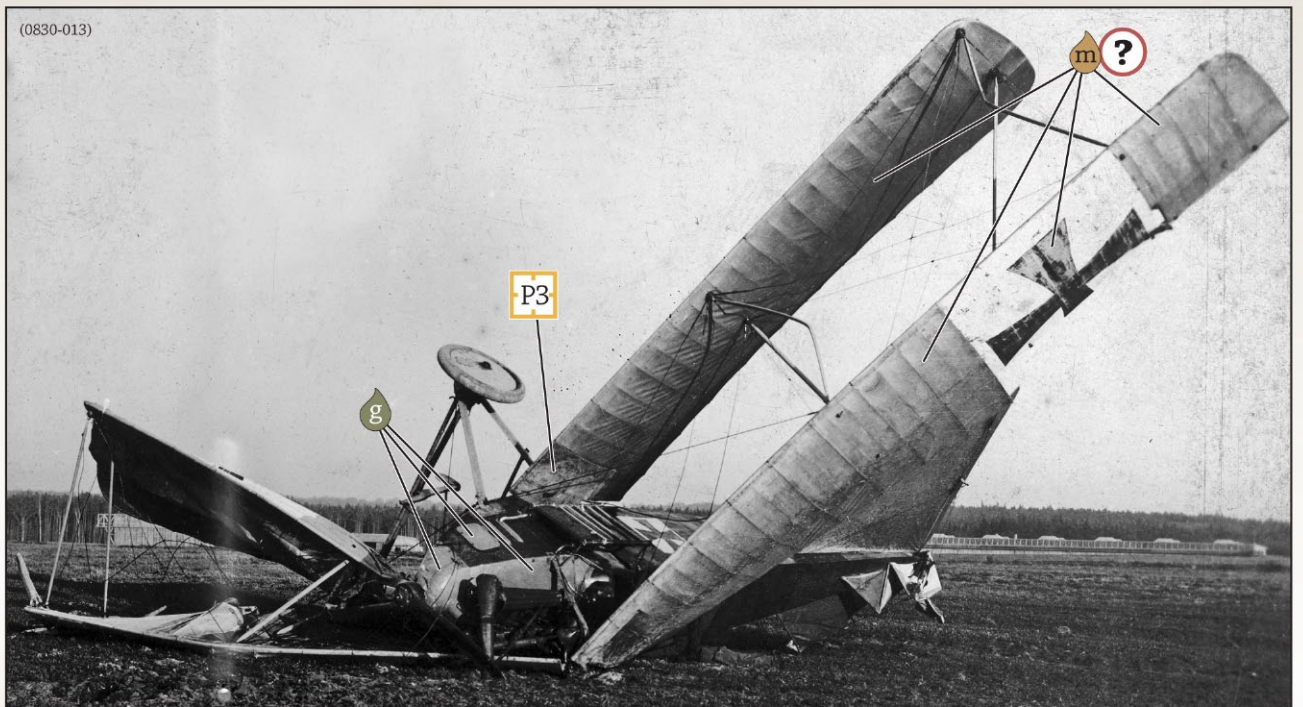
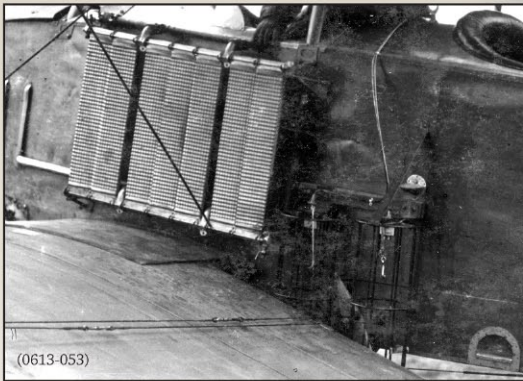

An unidentified crashed Albatros B.II. The grey-green painted louvers, hatches and engine cowlings stand out against the dark fuselage. There is fabric 'shielding' on the front 2 Hazet radiator panels to prevent over cooling. Note the 'upside down elephant' exhaust and how the black paint of the starboard top wing eisenkreuz has worn away revealing the unbleached linen fabric beneath.

6 NOSE DETAILS

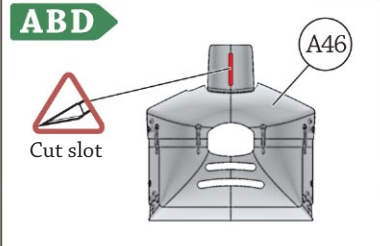
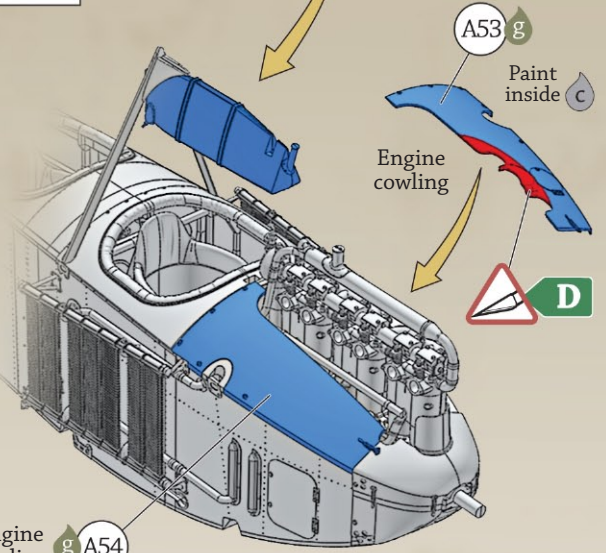
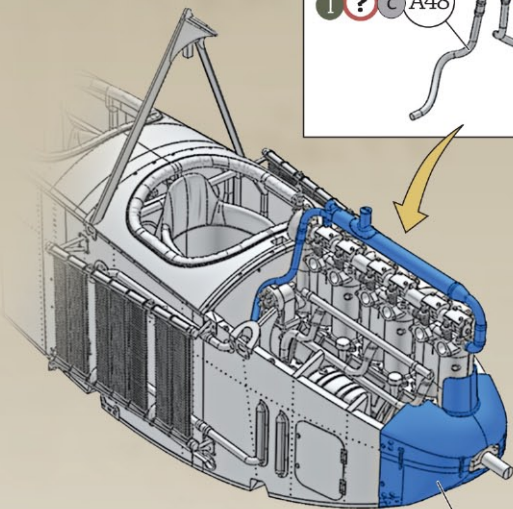
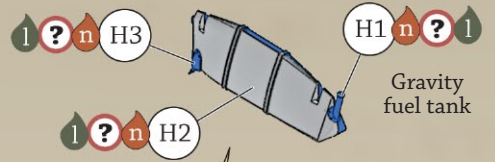
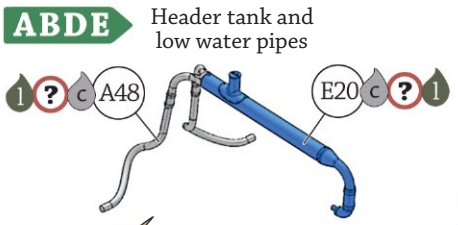

A46 g Nose cowling
Paint inside c

Engine cowling g A54
Paint inside c

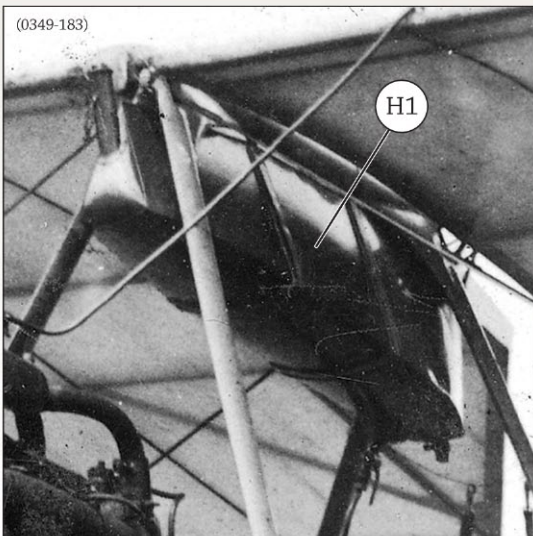
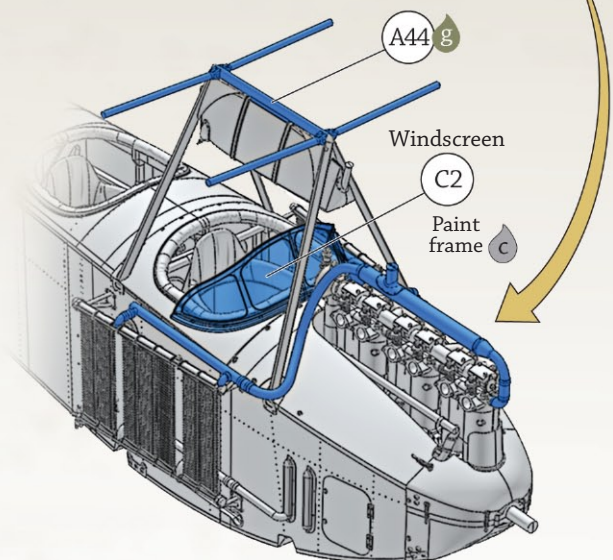
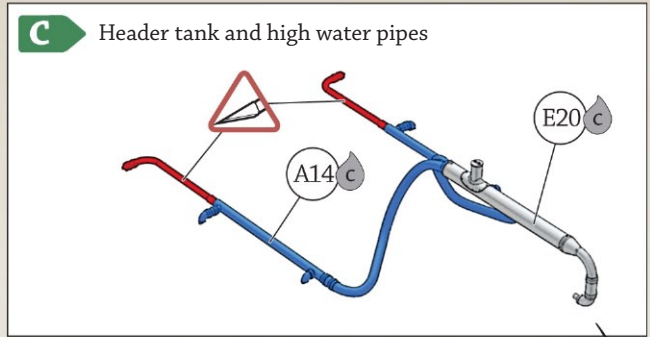
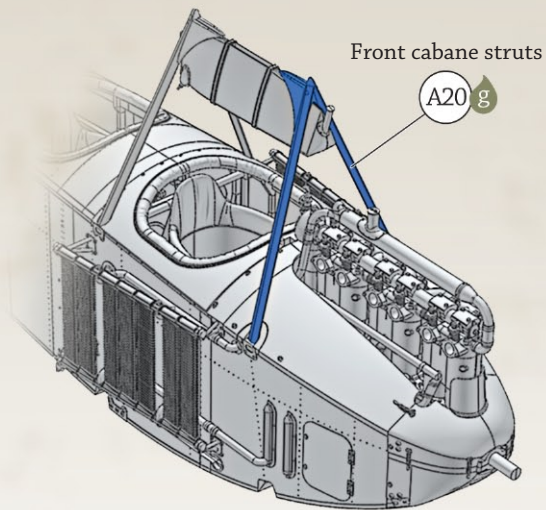

Gravity tank detail from Albatros B.II 847/15 **D**. Note the filler pipe at the front and drain at the rear.

7 BOTTOM WINGS AND TAILPLANE

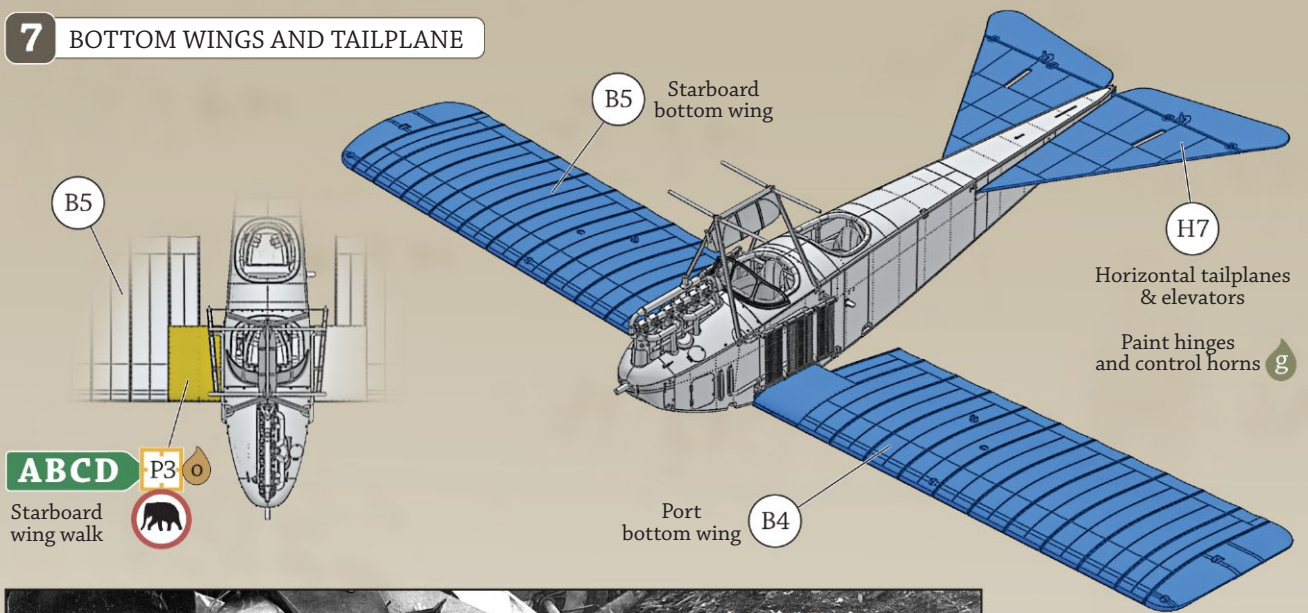

Tailplane detail from an unidentified crashed Albatros B.II showing factory applied 'sponge rolled' camouflage finish on the upper surfaces.

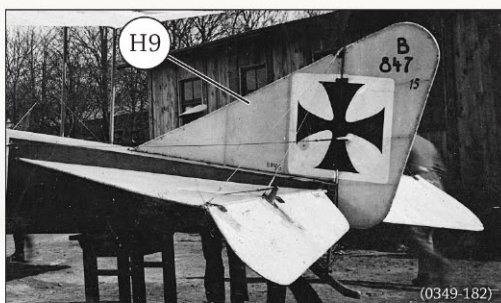
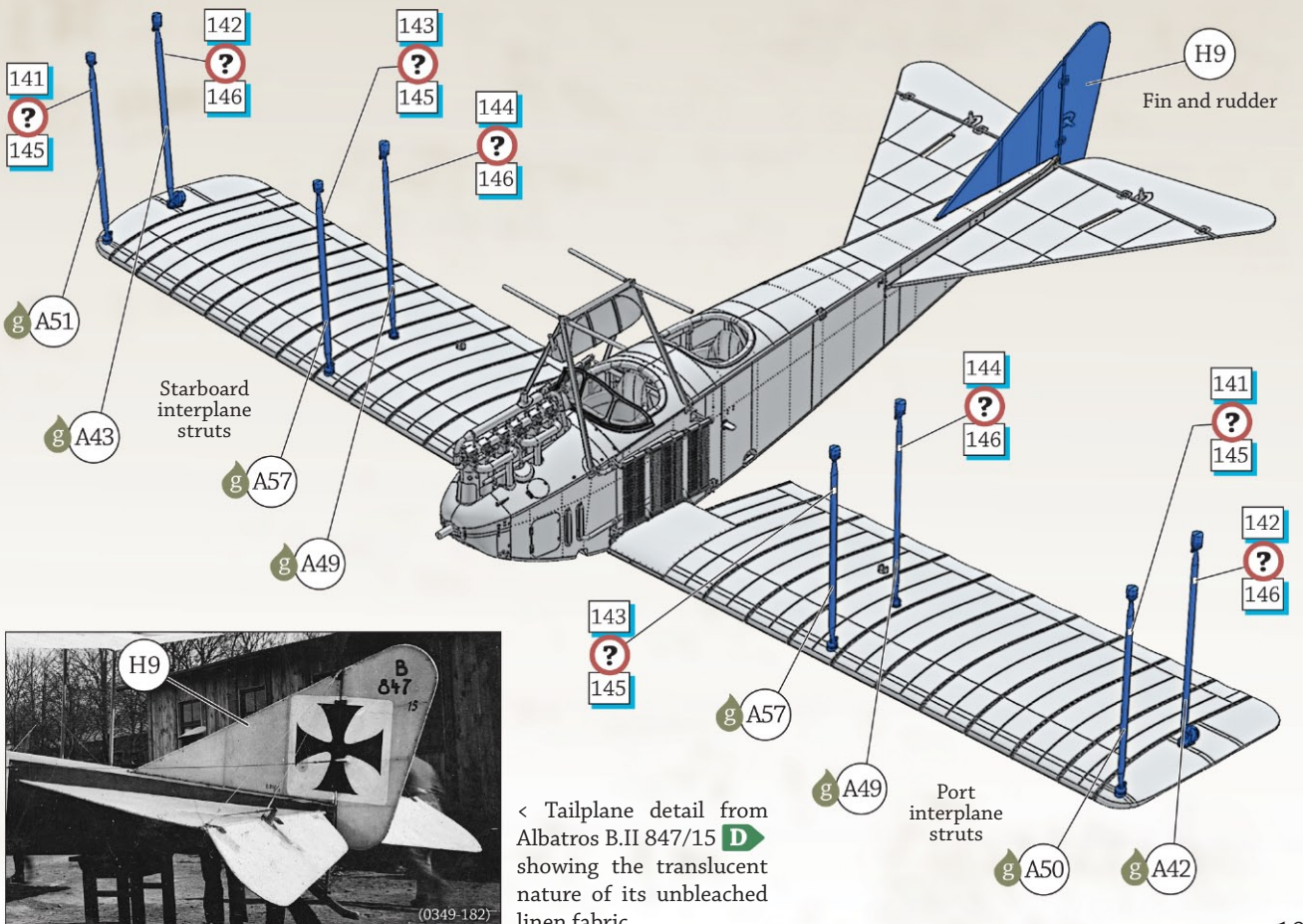

< Tailplane detail from Albatros B.II 847/15 **D** showing the translucent nature of its unbleached linen fabric.

8 TOP WINGS AND UNDERCARRIAGE

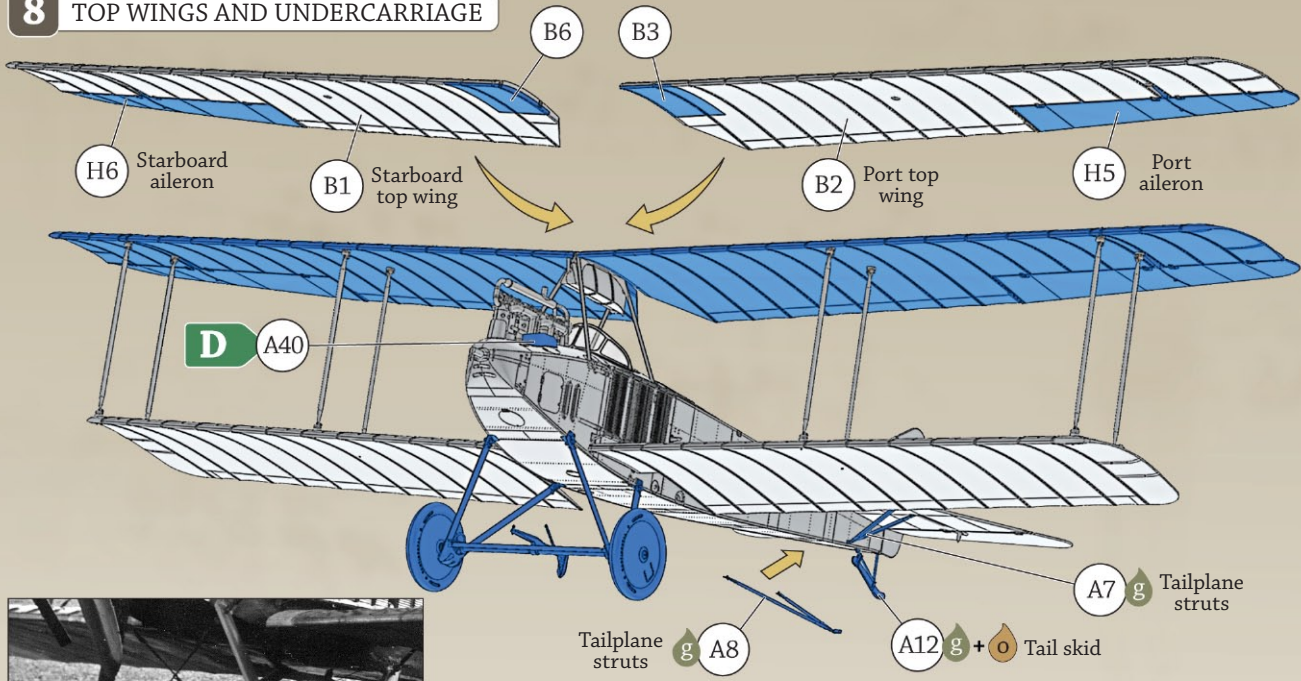

< Undercarriage detail from the unidentified Albatros B.II seen on page 23. Note the claw brake spring wired to the undercarriage bracing cables and the uncovered wire wheels. The suspension bungee cords are protected by leather bags.

D Covered wheels **x2**

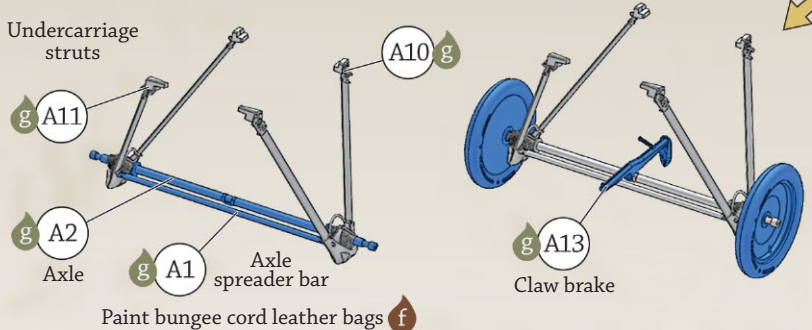

ABCE Uncovered 'wire' wheels **x2**

Paint rim & spokes **g**

? High detail (Experienced modellers only)

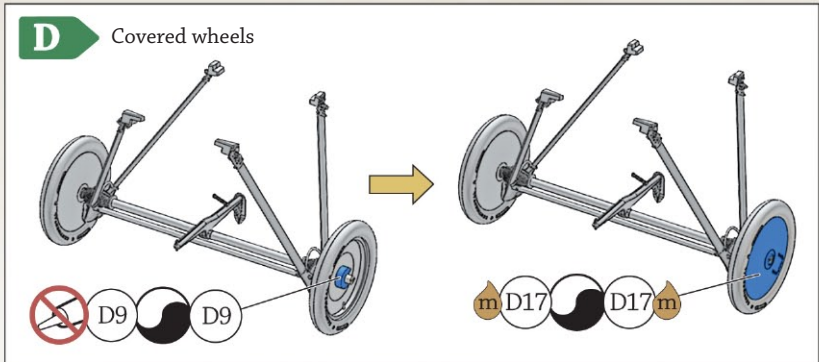

CDE **?** **v** 12.5kg PuW bombs and rack (1916 onwards only)

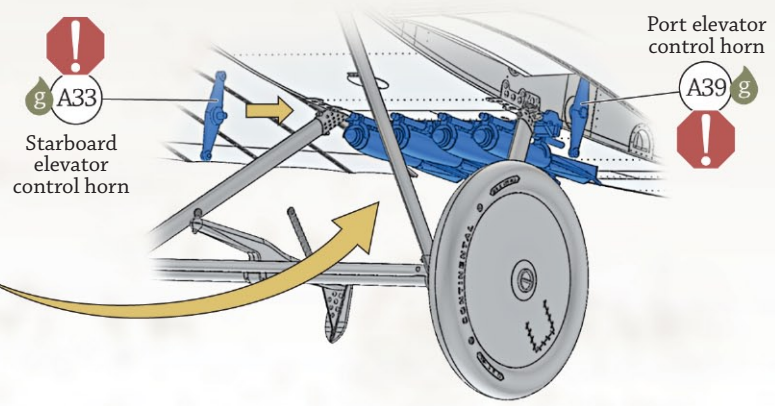

9 FINAL ASSEMBLY

CDE 'Elephant' exhaust manifold

A ?

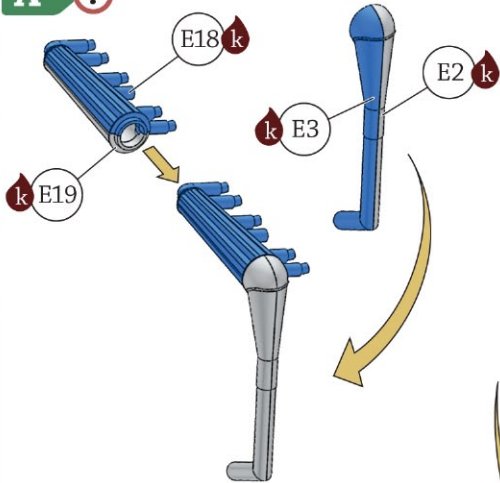

AC ?

B E26 e
Garuda propeller

DE E11 e + o
Reschke propeller

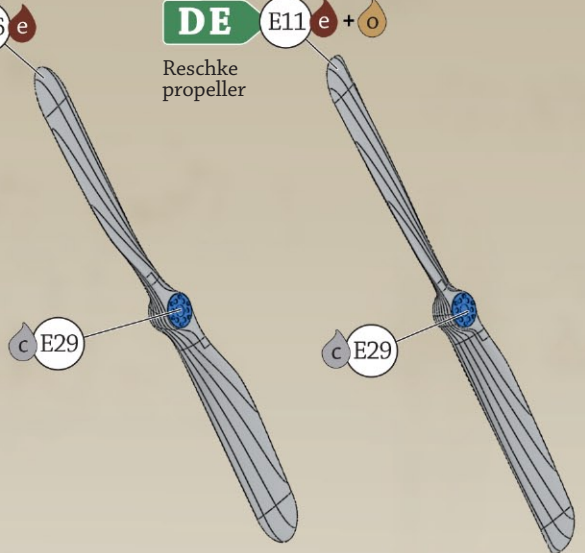

Optional accessories

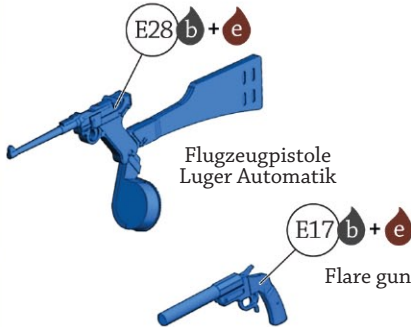

CDE ? vi x2

20kg Carbonit bombs (1914-1916)

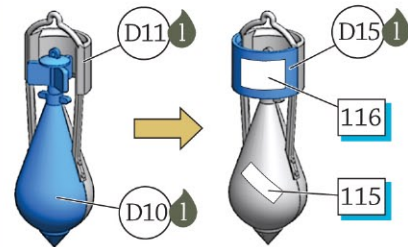

Drill out ends of exhaust pipes for improved detail

Individual exhaust pipes x6
A ?
B E31 k

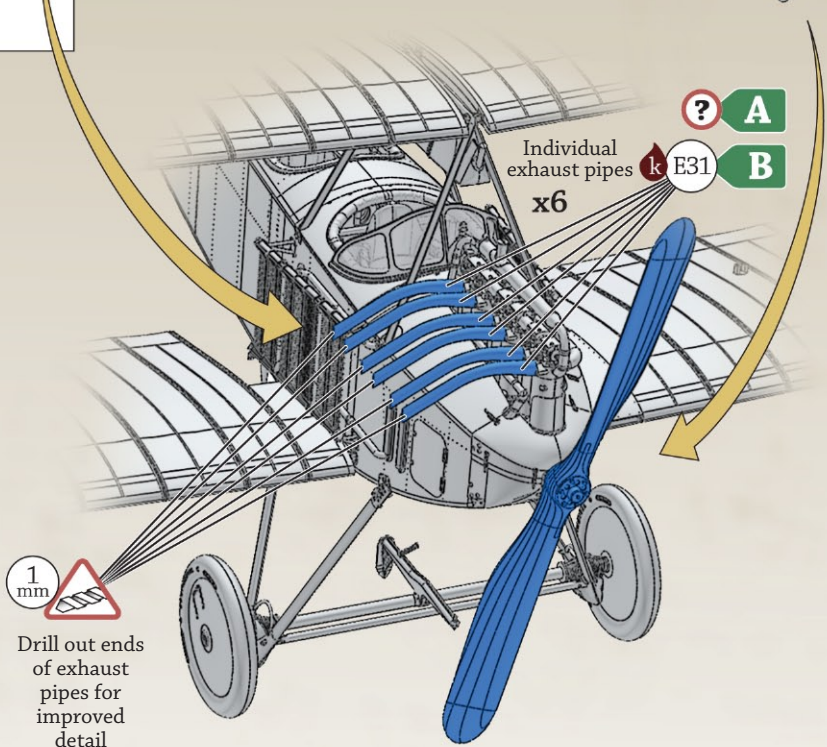

∨ This 120hp Daimler-Mercedes D.II engine powered Albatros built B.II served with the Navy and features individual exhaust pipes and uncovered wire wheels.

(0615-007)

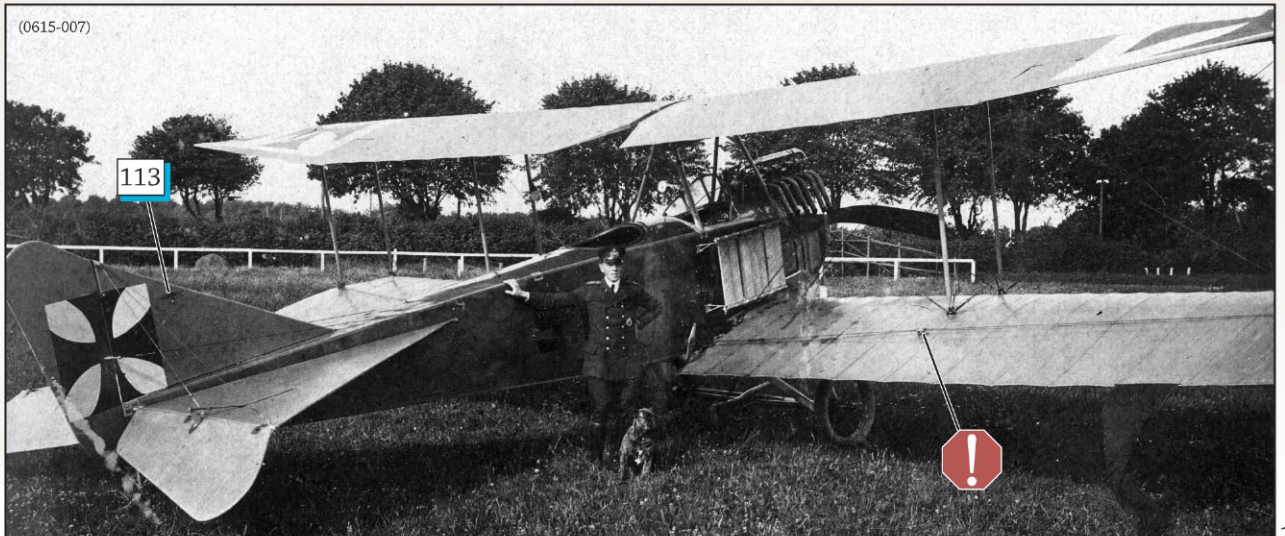

Rigging material not supplied

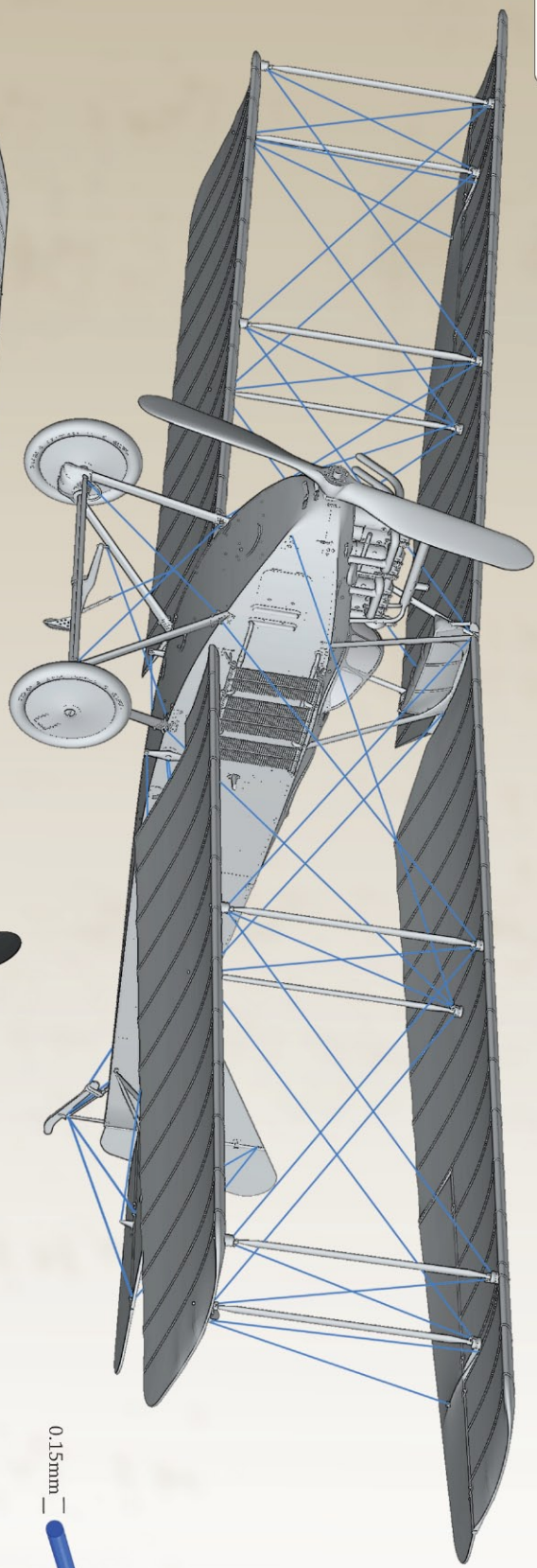

0.15mm 

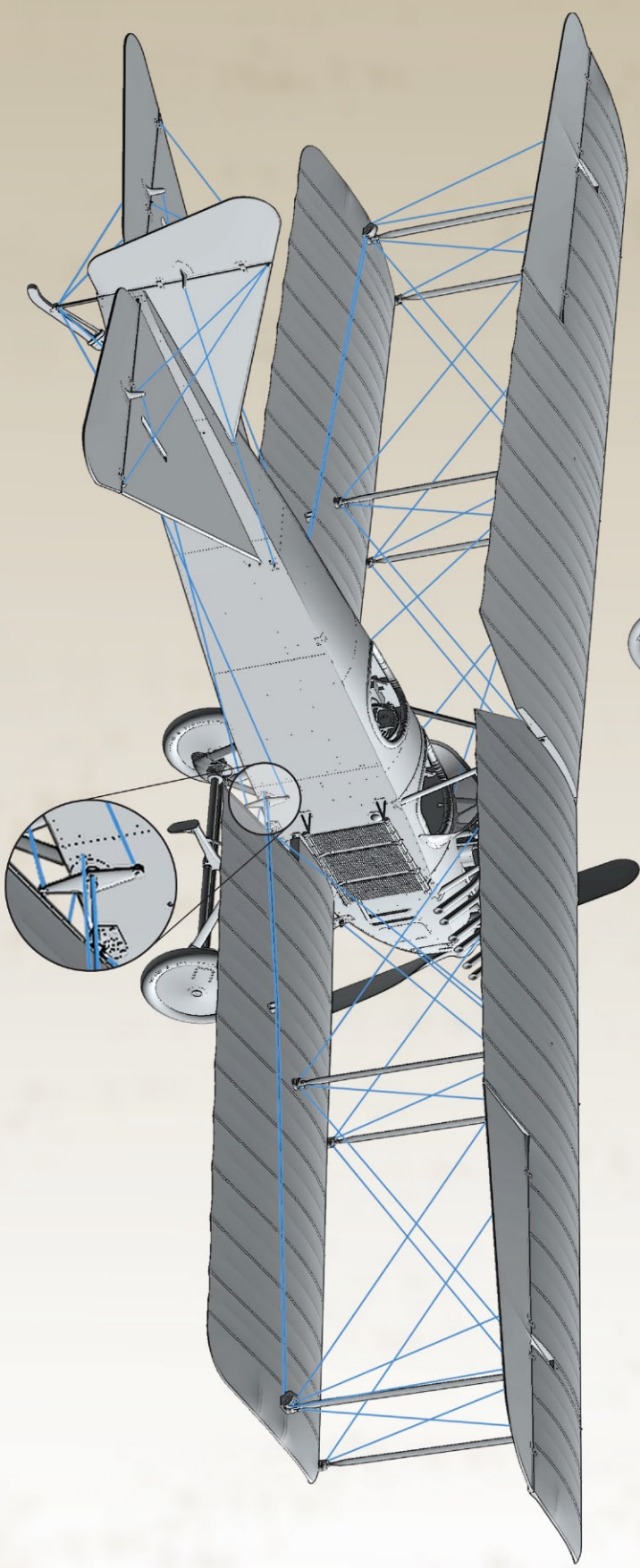

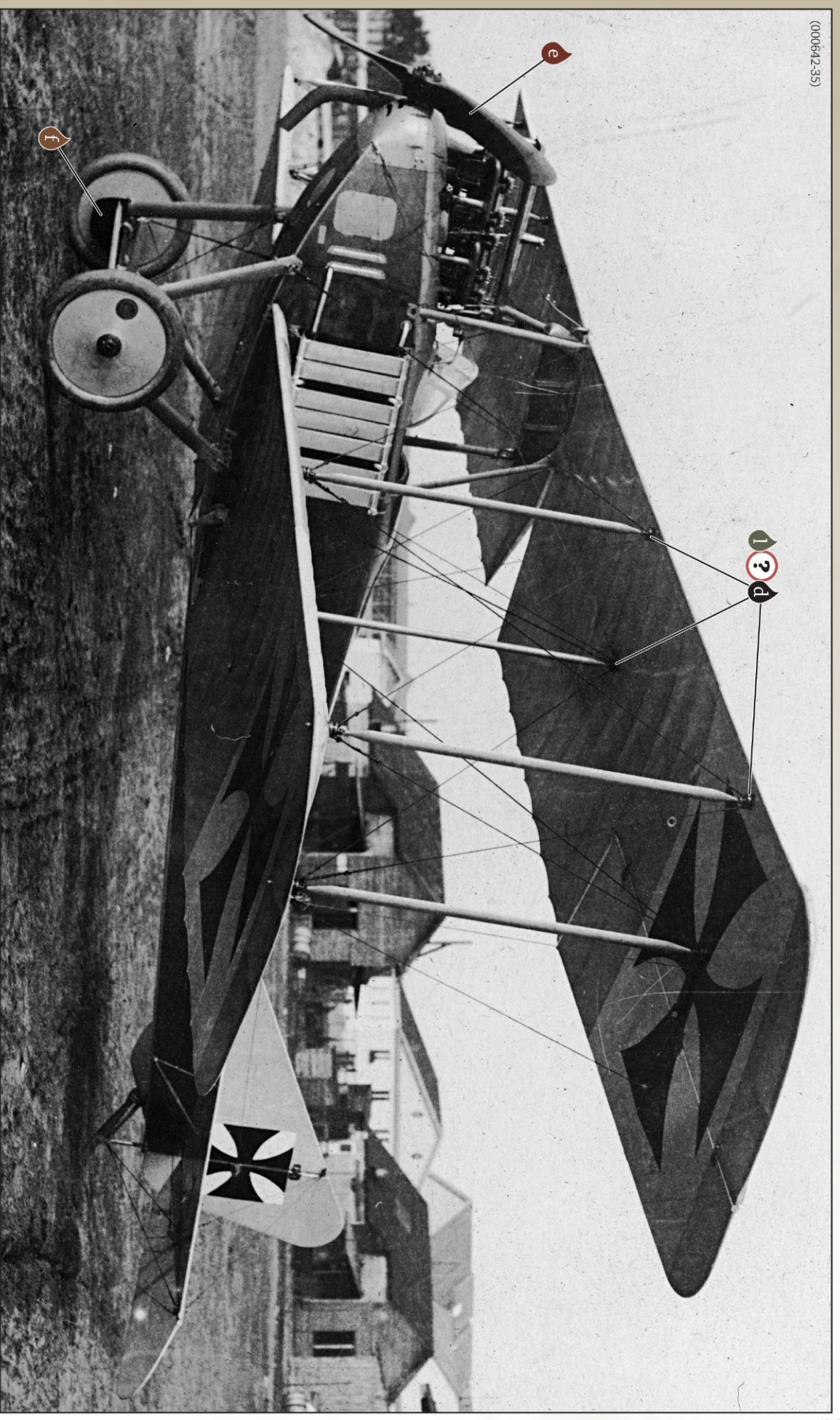

This unidentified 100hp Daimler-Mercedes D.1 powered Albatros B.II displays many characteristic features found on newly delivered early production aircraft; the dark appearance of the varnished plywood fuselage, clear doped linen (translucent) tailplane, painted or possibly dyed linen (opaque) wings, light grey-green metal hatches & panels and eisernkreuz applied under the top wings. Like many Albatros B.II certain anomalies can be found if you look close enough; the rear of the observers cockpit coaming has been removed and the tyre valve is covered with a round patch.

A Albatros B.II 210/13, Albatros built, 1915-1916

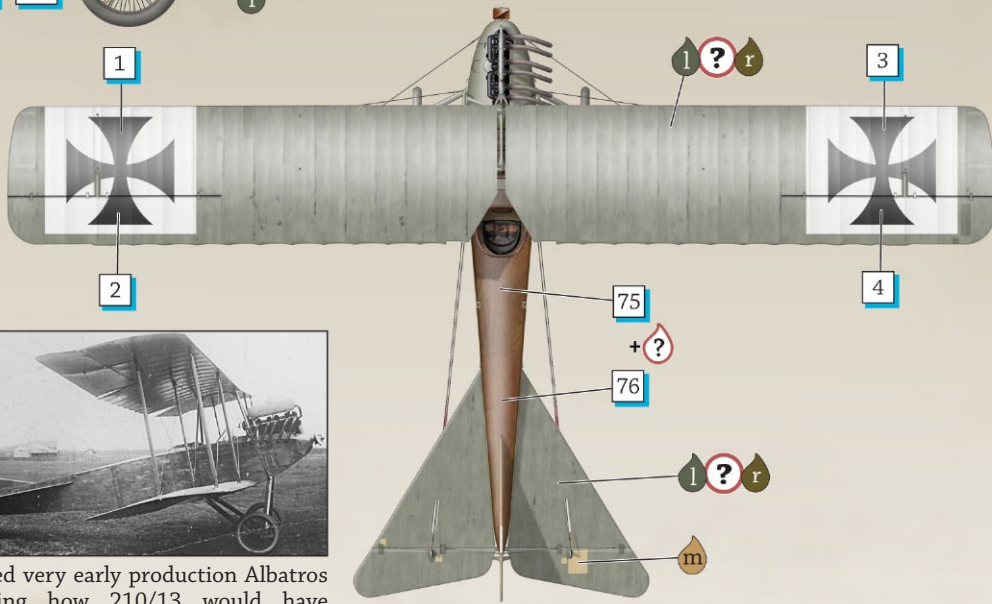

Unidentified very early production Albatros DD showing how 210/13 would have appeared in early 1914.

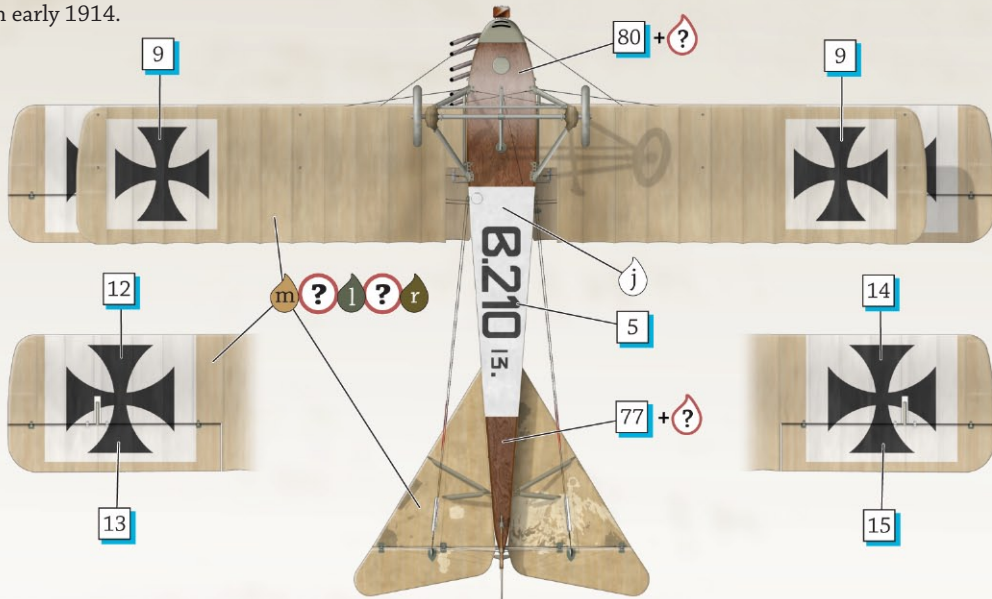

Production records are incomplete but Albatros built B.II 210/13 was one of the first few aircraft to be manufactured. It was factory tested alongside Albatros B.1(?) 209/13 in January 1914 and impressed by climbing to 800m (2625ft) in just 5 & ½ minutes. At the time of this record setting flight, Albatros DD (as it would have been known before the naming convention was changed in August 1915) 210/13 would have had a Scheitelküler radiator mounted above the engine and the smaller fin and rounded rudder associated with very early production aircraft. By the time the photos opposite were taken, Albatros B.II 210/13 appears to have been powered by a 120hp Daimler-Mercedes D.II engine and been brought up to date by retrofitting the larger fin & triangular rudder (salvaged from another aircraft) and side mounted Hazer radiators. Note the variety of eisernkreuz markings in 10 locations.



(000647-29)
Albatros B.II 210/13 has crashed into a ditch beside some railway tracks. Note the pilot's safety belt hanging from the rear cockpit opening and the mismatched, heavily patched, tailplane components.



(000647-28)
Note how the white fields of the eisenkreuz on the top wings extend to the leading edge but stop short of the trailing edge of the ailerons, this is a relatively common trait amongst Albatros built B.II.



(000647-27)
The heavily weathered and patched tailplane is obvious in this photo. A large portion of the bottom of the fuselage appears to have been painted white so that the oversize serial number was more visible from the ground, indicating that Albatros B.II 210/13 was probably being used for training at the time of this crash. Note the dark material **w**? wrapped around the elevator control cables where they cross 'over' each other.

B Albatros B.II, MAN built, April 1915

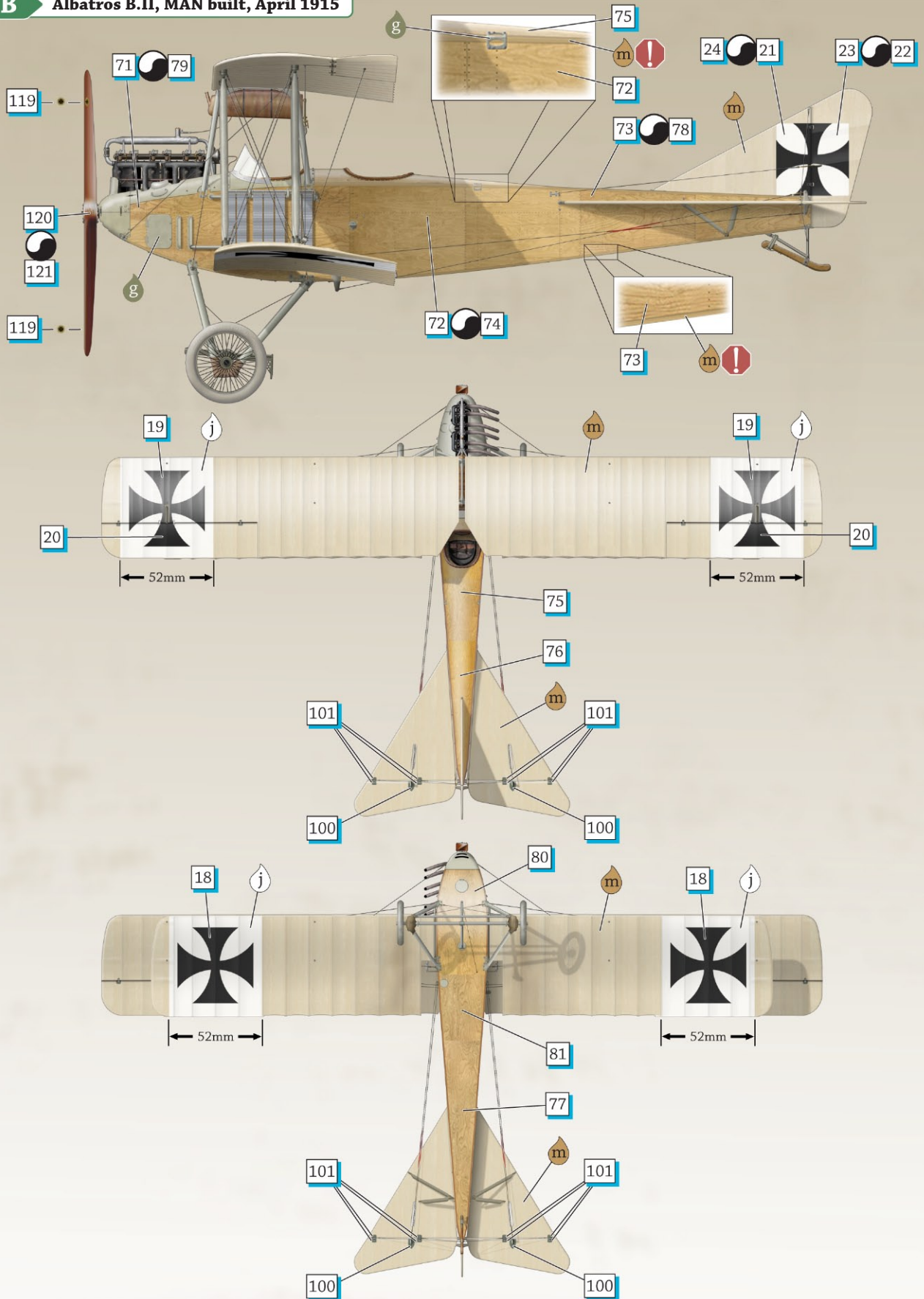

This unidentified Maschinenfabrik Augsburg-Nürnberg (MAN) built Albatros B.II was photographed on 10 April 1915 at the factory grounds and two images can be seen in Windsock Datafile 93. The caption mentions that it was powered by a 100hp Daimler-Mercedes D.1 engine which was incapable of achieving the accepted 'climb to height' performance required at the time. Curiously the photos appear to show this aircraft with a 120hp Daimler-Mercedes D.II engine installed and were possibly taken after it had been re-engined following the unsuccessful trial. The fuselage is pale varnished plywood with grey-green metal panels & brackets while the wings and tailplane appear to be unbleached linen. Note the early eisenkreuz markings in only 6 locations.

C Albatros B.II 676/15, 1916

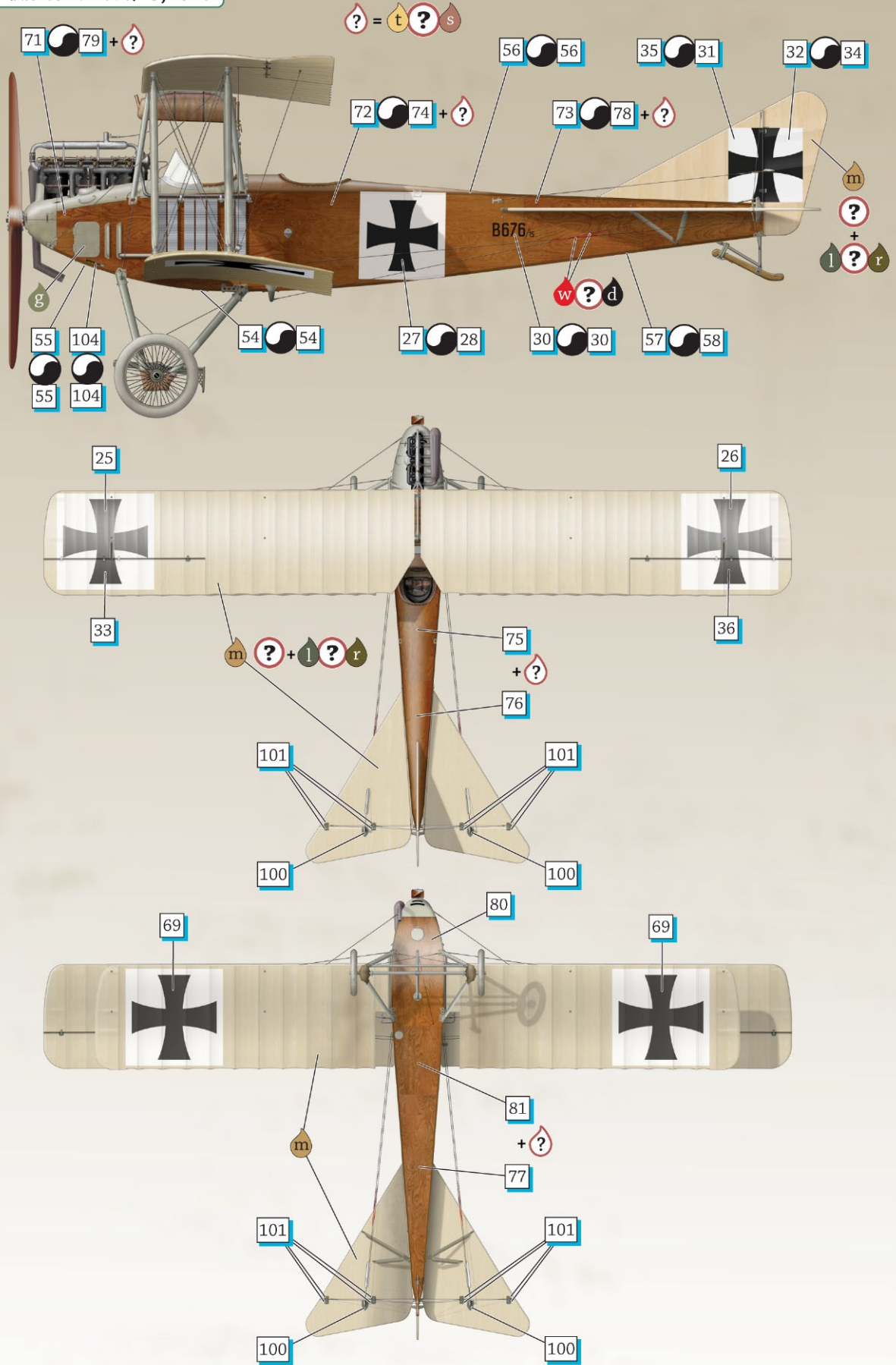

A photo of Albatros B.II 676/15 can be seen in Windsock Datafile 93 which shows a darkly stained fuselage, uncovered wire wheels and high mounted radiator pipes (A14). The wings and tailplane appear to be unbleached linen but could possibly be finished with a tightly speckled camouflage finish on the upper surfaces as seen on page 10. Late style eisernkreuz can be seen in 8 locations. Although the image available to us is not very clear it appears to be powered by a 120hp Daimler-Mercedes D.II engine.

D Albatros B.II 847/15, 1915-1916

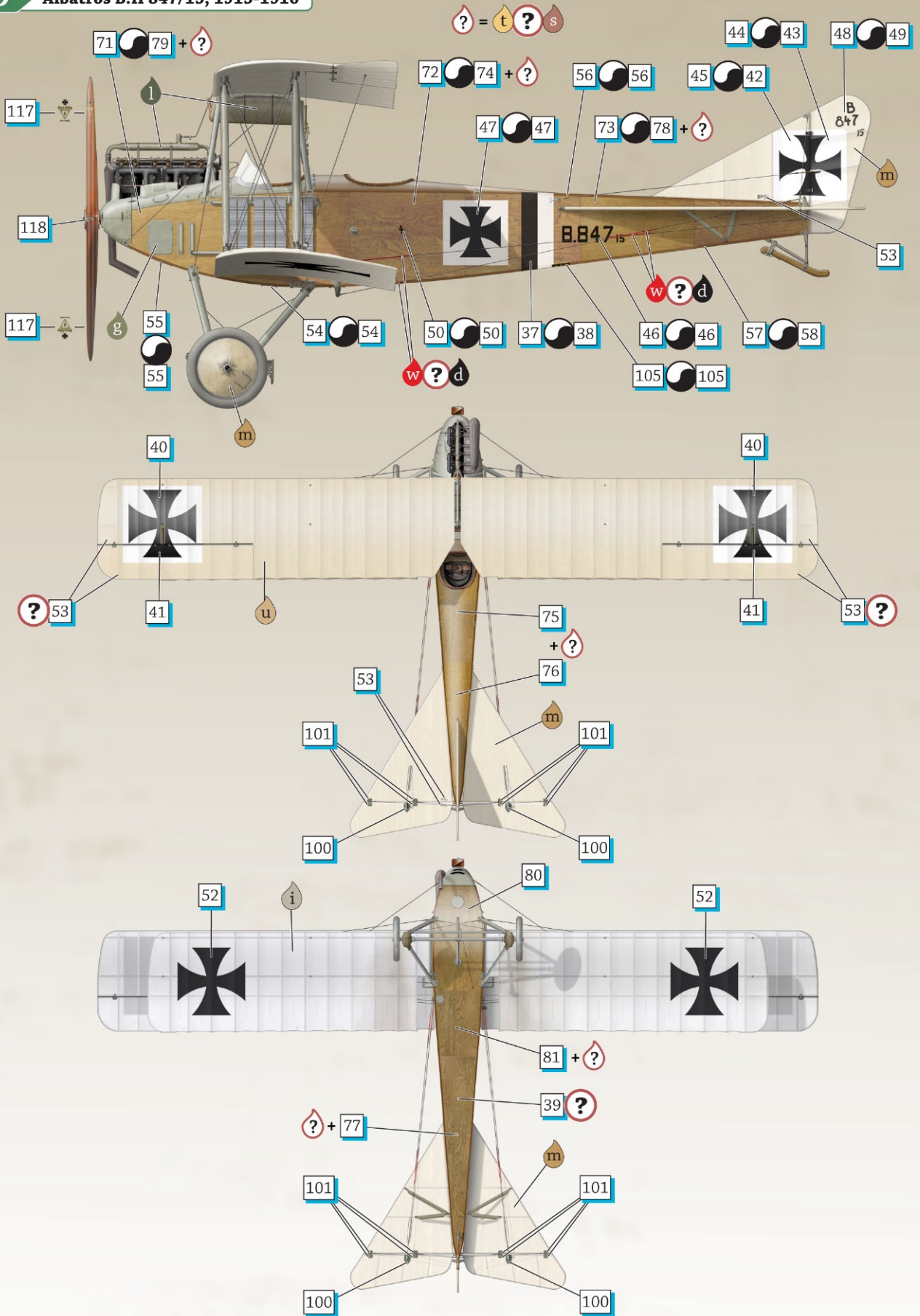

120hp Daimler-Mercedes D.II powered Albatros B.II 847/15 features a varnished plywood fuselage with light grey-green metal panels & brackets and struts. The tailplane appears to be unbleached linen. The black and white bands on the sides (and possibly the bottom) of the fuselage may indicate that Albatros B.II 847/17 served with Armee Abteilung Gaede in late 1915. Early eisernkreuz markings can be seen in 8 locations with those on the underside of the bottom wing not appearing to have white fields, indicating bleached (white) linen undersides.

(0349-182)

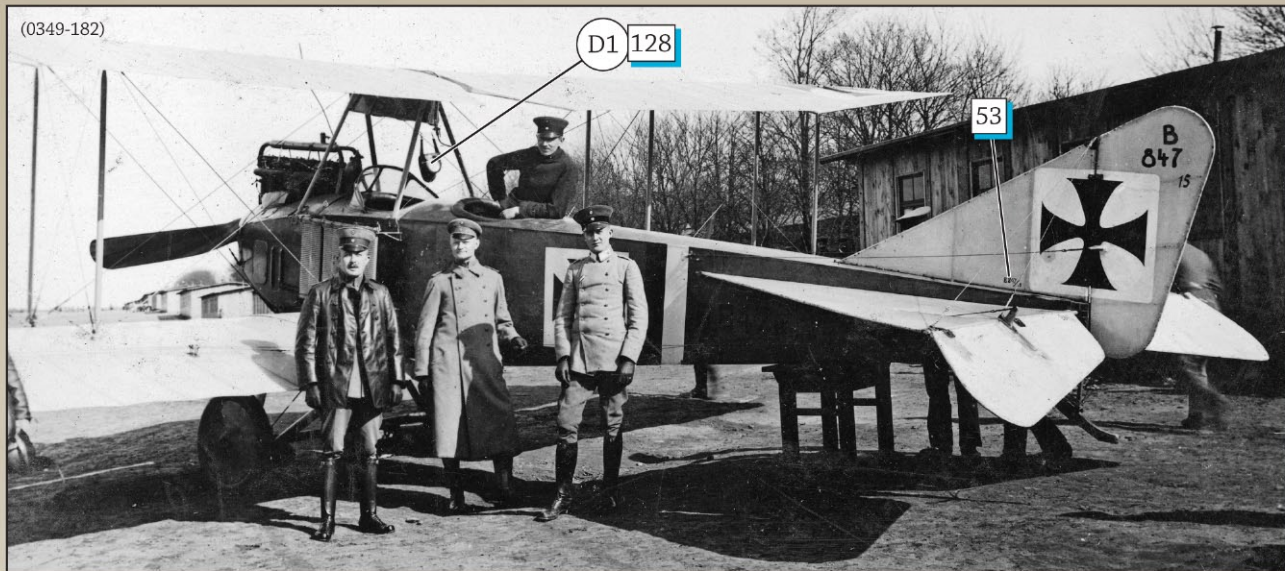

^ Albatros B.II 847/15 rests its fuselage on a small table while being prepared for flight. Note the rounded corners of the white field on the fin & rudder and the curved inner area of the eisenkreuz. The translucent nature of the linen covering the fin & rudder allows shadows of the internal steel tube framework to be visible. The serial number 'B 847/15' is repeated on the fin, horizontal tailplane and elevators.

(0349-183)



< The unidentified crew of Albatros B.II 847/15 pose before their flight. Note the Reschke propeller (E11), rough fairing covering the carburetors (A40) and altimeter (D1) strung between the rear cabane struts. The translucent nature of the wing fabric allows the internal structure to be partially visible. The undersides of the wings appear to be bleached (white) linen negating the need for painted white fields for the crosses while the top surface has been treated with a colour sufficiently dark enough to require white cross fields.

> Ready for action, the crew of Albatros B.II 847/15 are wrapped up for protection from the elements at altitude. Note the aileron control cables passing through the raised fairleads on the bottom wing, small number 4 [50] on the fuselage and how the black and white bands do not extend over the top of the fuselage.

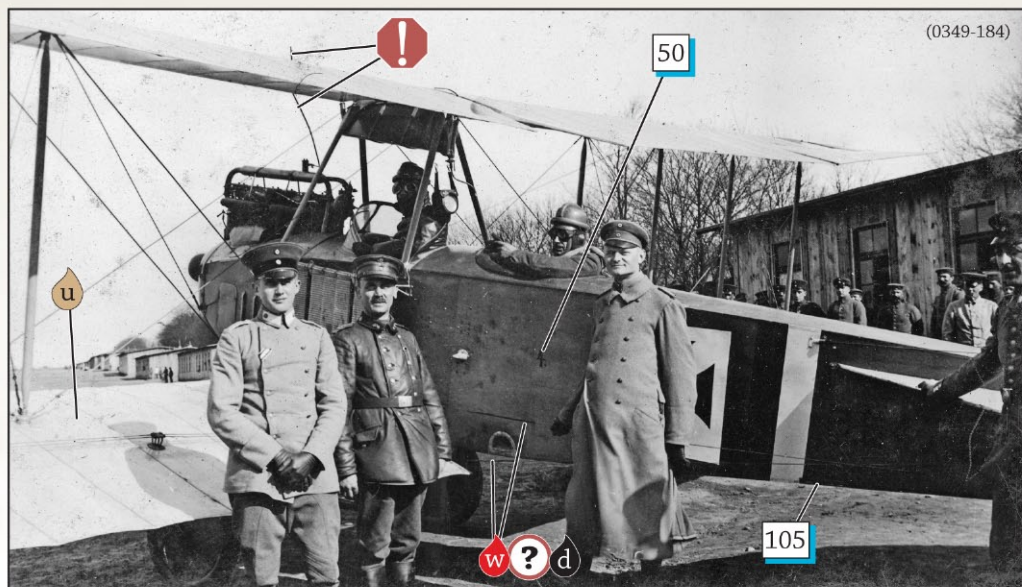

(0349-184)

E Albatros B.II 1131/15, 1916

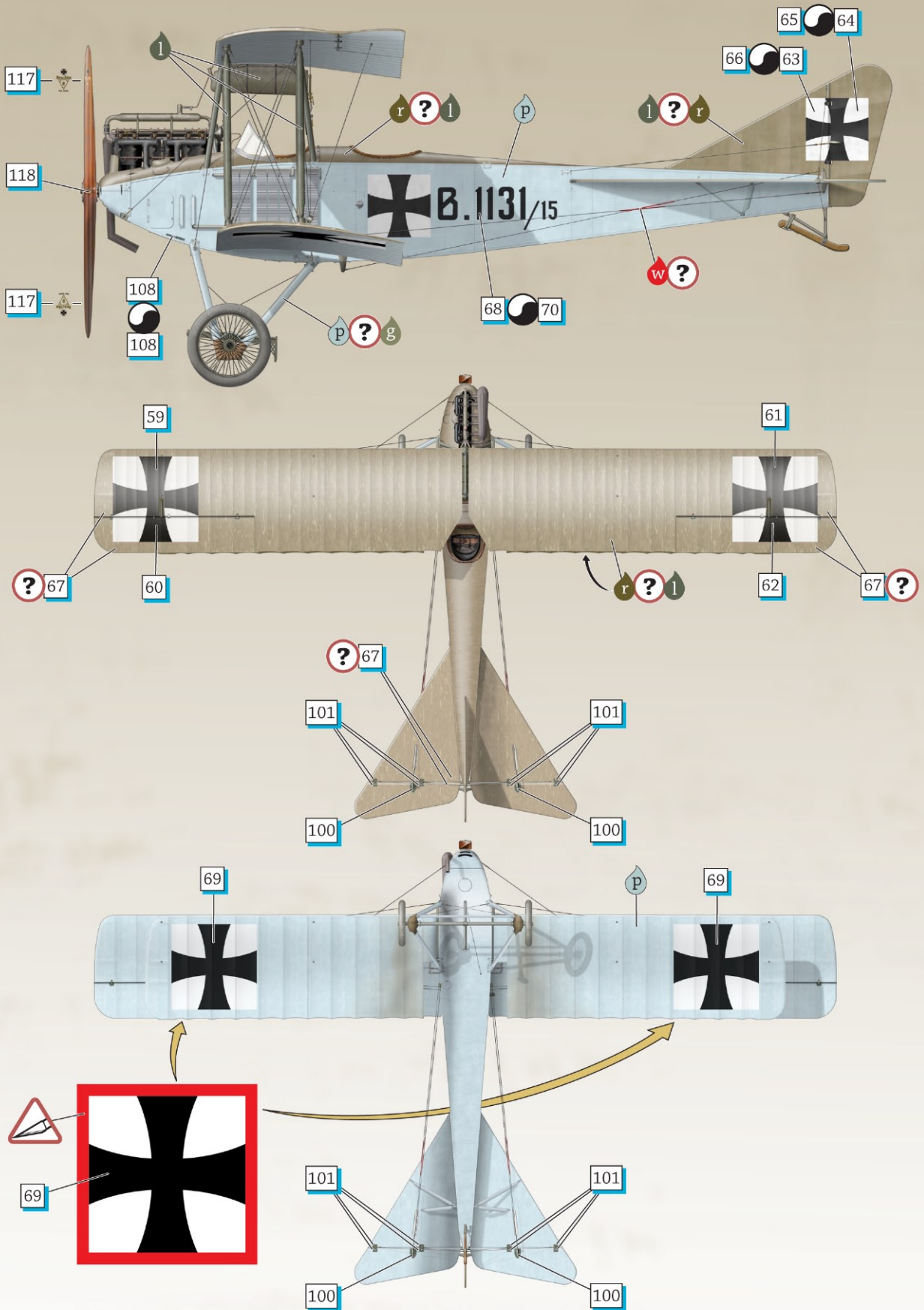

Albatros B.II 1131/15 is depicted here in a camouflage scheme of light blue with roughly applied dark camouflage paint on all upper surfaces. Although the true colours are unconfirmed they are based on what is understood about early German camouflage practices and are consistent with what can be seen in the photo of 1131/15 in Windsock Datafile 93. This photo shows an unevenly applied upper surface camouflage colour and heavily exhaust stained starboard bottom wing, fuselage and horizontal tailplane. Unfortunately it is not possible to determine if 1131/15 was powered by the 100hp D.1 or 120hp D.II Daimler-Mercedes engine from the photographic evidence available to us at this time.

(000647-48)

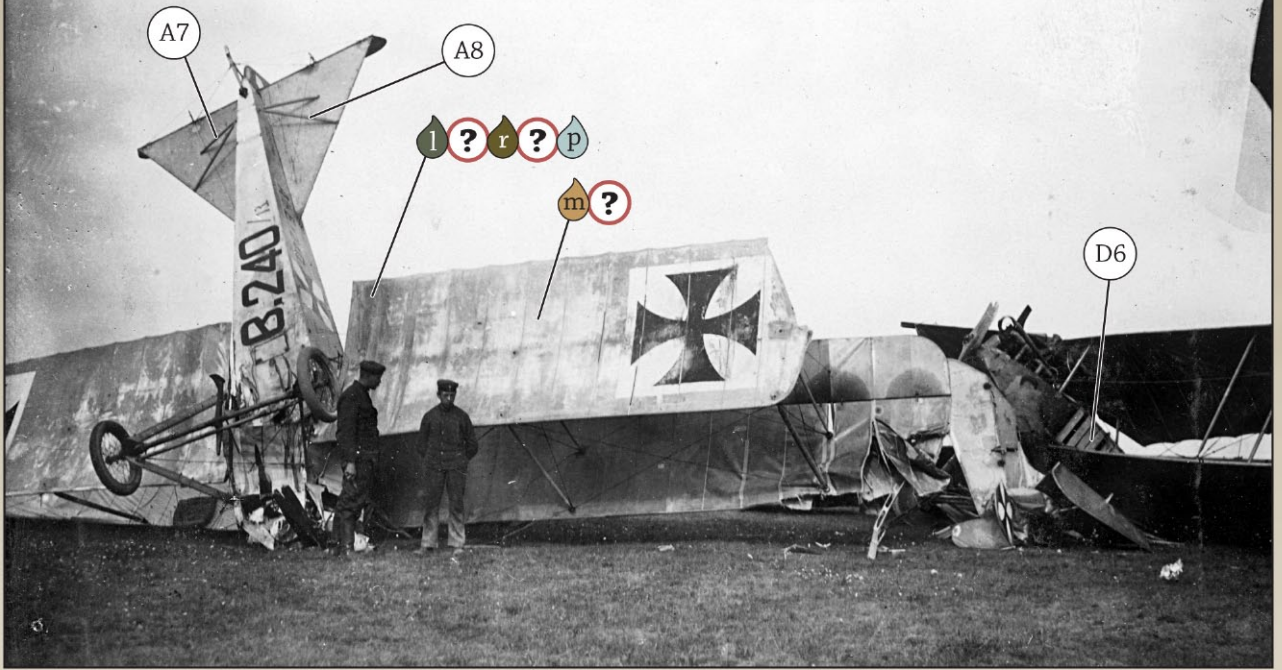

These well weathered and patched Albatros B.II have come to grief and are almost certainly stationed at the same fliegerschule as 210/13 **A**. Albatros B.II 240/13 is a very early production machine which appears to have been successively updated as replacement parts, no doubt scavenged from other damaged aircraft, became available. Note the heavily weathered, repainted and 're-rib taped' wings. The unidentified Albatros B.II on the right has been completely cut in half and features side mounted Hazet radiators and a vertical exhaust manifold.

(000647-49)



The remains of the severely damaged Albatros B.II seen in the photo above. The heavily patched wings are noteworthy, 3 of which appear to have been covered in fabric which was painted in a suitable camouflage colour. The bottom port wing appears to have been overpainted with an opaque pale colour, perhaps **p** or **u**. Note the pilot's seat and destroyed cockpit coaming padding in the foreground. The heavily ribbed and un-aerodynamic wing walkways appear to have been applied to numerous school aircraft.

(0935-021)



This unidentified Albatros B.II is powered by a 100hp Daimler-Mercedes D.1 engine and features uncovered wire wheels, a thin version of the 'elephant' exhaust and a darkly painted propeller. Note the opaque wing fabric precluding a CDL finish. The airman is noted as being 'Unteroff Breidr' and is not wearing any identifiable pilot or observer badges.

(0465-021)

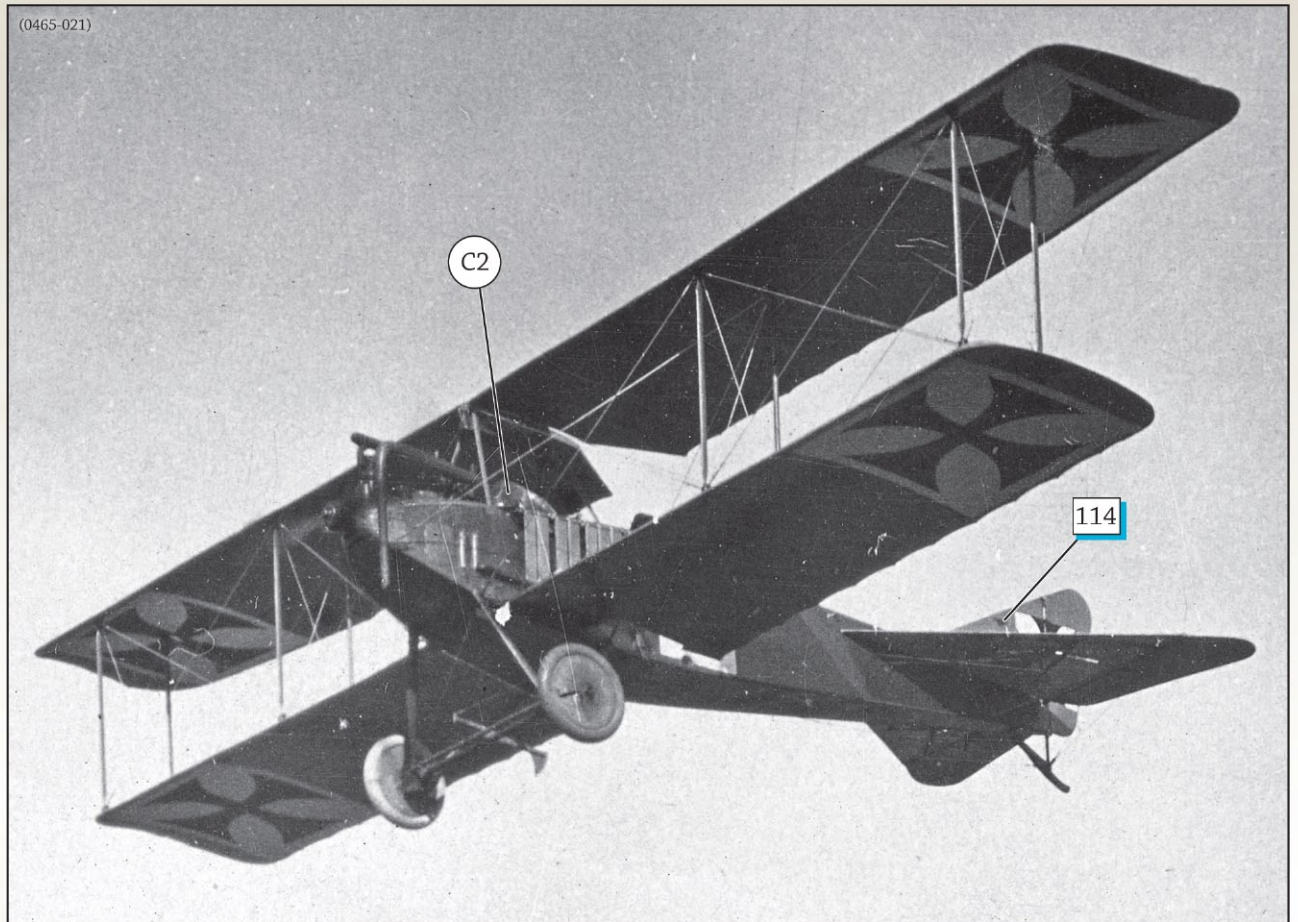

An unidentified 110hp Benz Bz.II powered Albatros built B.II in flight. The completely opaque nature of the wing and tailplane fabric precludes a CDL finish.

(0634)



Roland built 110hp Benz Bz.II powered Albatros B.IIa in Polish service with stick type control column, radiator in front of the top wings and large balloon type tyres. The thick wooden interplane & undercarriage struts are an identifying feature of later production B.IIa. Note the Albatros C.1 style tail skid and tailplane bracing frequently found on late production B.II or retrofitted to older aircraft.

(0547-139)



(0424-004)



The occupants of this unidentified Albatros built B.II appear to have escaped serious injury following a rough landing. Note the overall dark, opaque, nature of the fabric surfaces, uncovered wire wheels and 120hp Daimler-Mercedes D.II engine.

(0830-012)

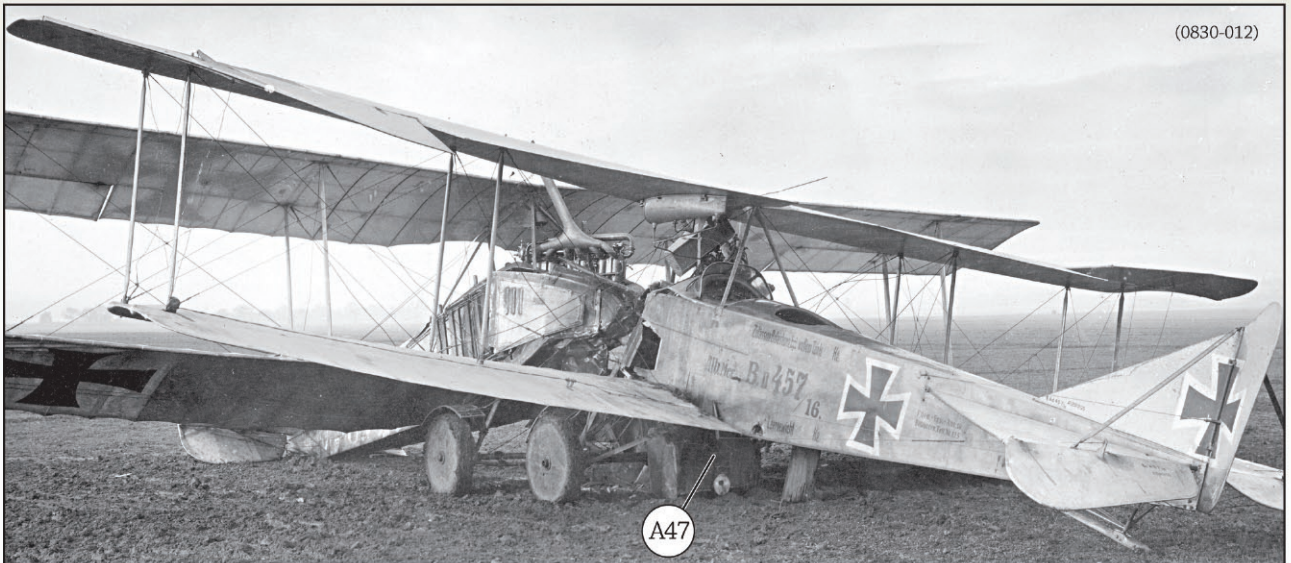

Mercur built Albatros B.II 457/16 trainer of FEA 10 has been involved in a collision with an Aviatik B.II. Both aircraft are powered by 120hp Daimler-Mercedes D.II engines and feature hollow wooden wheels that are frequently seen on training aircraft along with wire mesh mud guards. On B.II 457/16, note the radiator fitted in front of the top wings, offset gravity fuel tank under the port top wing, Albatros C.1 style tail skid and fin bracing struts. The square object under 457/16 is the main fuel tank which has fallen through the bottom of the fuselage.

(0547-006)

> This unidentified 110hp Benz Bz.II powered Albatros B.II has been fitted with jury rigged armament consisting of a captured Lewis gun on a makeshift mount. Note the unusually large gravity fuel tank under the starboard wing and the additional Hazet radiator panels (D5).

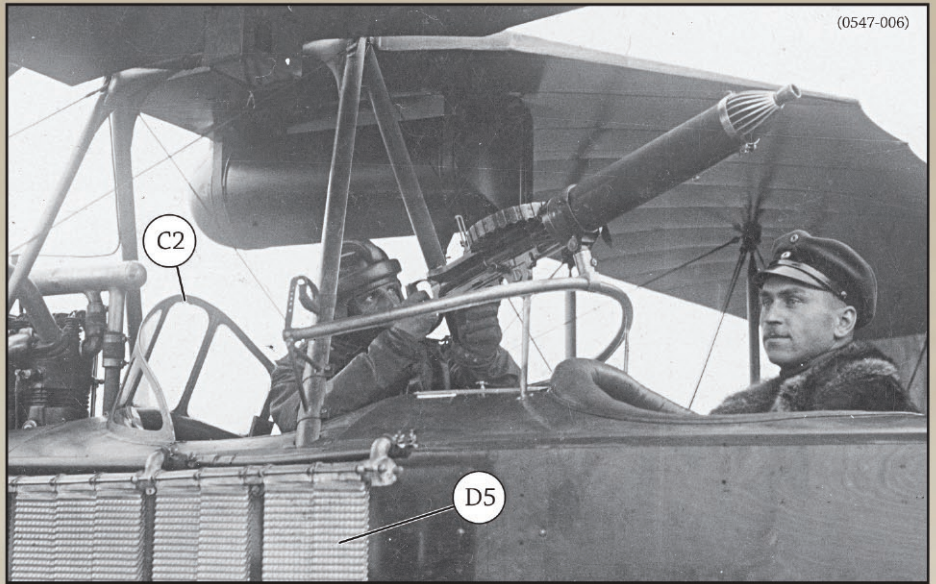

(0684-067)

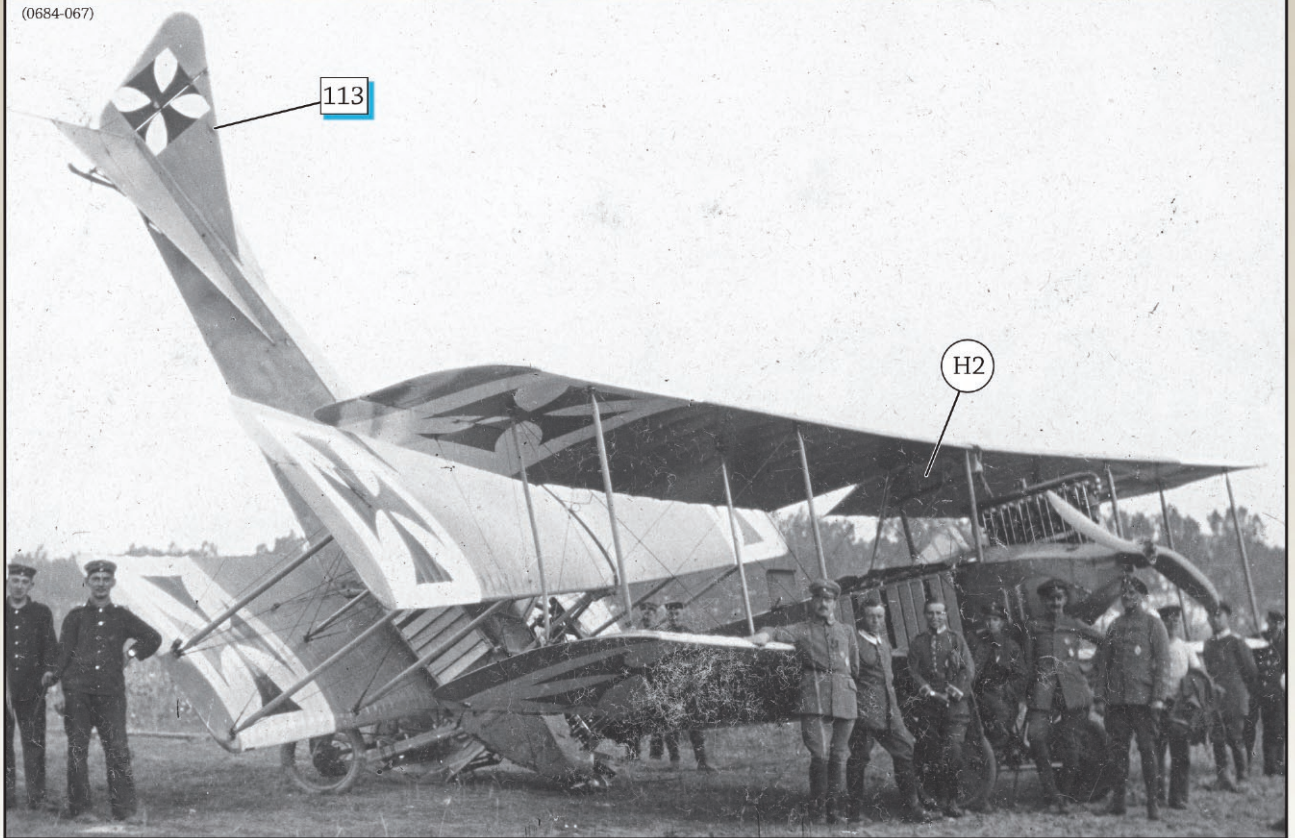

Two unidentified 110hp Benz Bz.II powered Albatros B.II which have come to grief.

(0156-104)

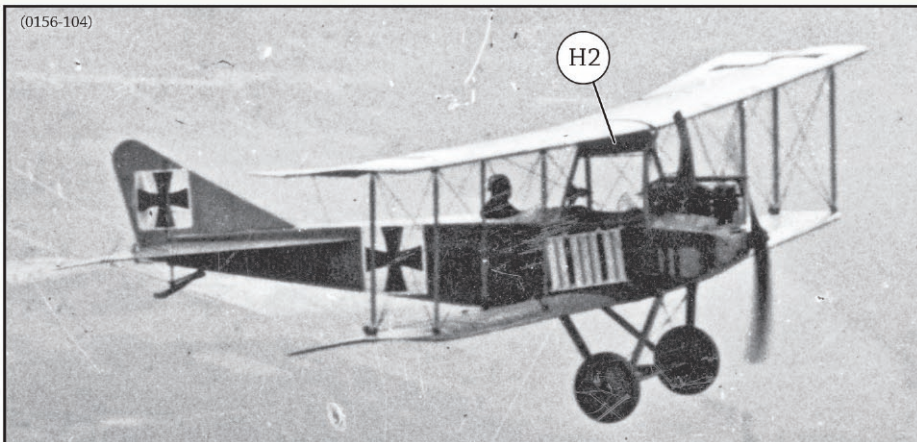

< An unidentified Albatros B.II in flight. The unusual angle of the Hazet radiator is an optical illusion caused by the angle at which it is mounted to the fuselage.



An unidentified pilot poses with 3 equally unidentified mechanics in front of 'their' Albatros B.II (or B.1) which has had its 100hp Daimler-Mercedes D.1 engine disassembled. The 'pinched' fabric trailing edge of the top wing has been noted on numerous early production Albatros B.II (and B.1) and could be replicated with careful painting on a model. Note the joined engine cylinders with short water jacket, header tank (E20) and the number of coils on the engine springs in the foreground.



3-D Modelling by Darren Mildenhall

Born and raised in Wellington, New Zealand, Darren harnessed his creativity by attending the School of Design, graduating with a major in Industrial design. During the degree he developed a passion for form and the aesthetic appeal of a product and how to utilise CAD software to realise and develop a concept. Joining Wingnut Wings as a 3D modeller has furthered his skill in these areas through the creation and manipulation of complex 3D forms.

When not designing WW1 model aircraft, Darren enjoys graphic based art and t-shirt design, a lot of which is influenced by his interest in pop culture, typography and the retro 1950s. Outside all that, Darren is a self confessed movie buff and sports fan.



Box Art by Steve Anderson

Steve Anderson is an avid historian of military aviation, with a special interest in the many beautiful biplanes and triplanes of World War I. The aircraft and battles of famous World War I aces such as Baron Manfred von Richthofen (better known as the "Red Baron"), James McCudden, Raoul Lufbery, Ernst Udet, Werner Voss, and other pioneers of dogfighting are among Steve's favorite subjects.

An Artist Fellow of the American Society of Aviation Artists, Steve creates works that reflect scrupulous attention to historically accurate detail, from the colorful markings on the fuselages to the time of day of an actual battle.

Visit Steve's website at: www.anderson-art.com.



Profile Art by Ronny Bar

Ronny Bar developed a keen interest in airplanes from an early age, living close to the El Palomar Air Force Base in Buenos Aires. He first flew in the back seat of a T-34 Mentor trainer at the age of ten, and was soon drawing airplanes and building models: Spitfires and Messerschmitt first... Camels and Fokkers later. He became a successful bass player with a career lasting over 35 years in several Rock bands, recording ten albums (one of them being a National hit selling more than 100,000 copies) and performing countless concerts, TV shows and tours all over Argentina.

Now retired from the R'n'R scene, his interest returned to his early passion: Aviation Artwork. Visiting the WW1 aircraft collection at Hendon focused his already growing interest for that historic period. His artwork is regularly appearing in journals and publications like Windsock Worldwide, Windsock Datafiles, Cross & Cockade and Over the Front.

Visit Ronny's website at: www.ronnybarprofiles.com



Project Co-ordinator, Richard Alexander

A native of Wellington New Zealand, Richard Alexander has a long term interest in military history, race cars & local drivers from motor sports golden era of the '60's. Other interests include mountain biking, scotch and cigars.

An accomplished modeller Richard's models have twice been awarded Best Overall in Show at IPMS(NZ) National Conventions and earned him the inaugural TamiyaCon(NZ) Master Modeller award (along with the associated trip to Japan) in 2001. Many of his works are in private collections around the world, though he no longer accepts commissions.

Richard has been in the model and hobby industry since 1991 and brings with him a keen eye for detail and a passion for ensuring our models are enjoyable to build. So if there is anything you don't like about this model, you can blame him.

If you do have comments, requests or suggestions, Richard is contactable at richard@wingnutwings.com



32046	1/32 Albatros B.II Early	Qty
0132046A	A parts	1
0132046B	B parts	1
0132046C	C parts	1
0132026D	D parts	1
132E0021	E parts Merc D.1/D.II engine	1
0132046F	F parts	1
0132046H	H parts	1
0132046P	Photo-etched metal parts	1
7132046	Instructions	1
9132046a	Decals	1
9132046b	Decals	1

If you have any damaged or missing parts please contact help@wingnutwings.com for assistance.



32021 - 1/32 Fokker E.1 Early



32028 - 1/32 AMC DH.2



32026 - 1/32 Roland C.II

Also available from
www.wingnutwings.com

©2015 Wingnut Wings Ltd. PO Box 15-319 Miramar, Wellington 6022 New Zealand.
 All rights reserved. Designed in New Zealand - Manufactured in China.